

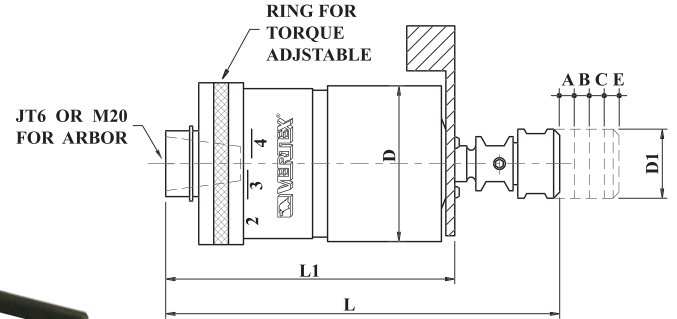

Reversible Tapping Attachments



- Radial Float is SELF-CENTERING to compensate for hole center misalignment.
- Unique Double Spring Mechanism produces Automatic Feed and Cushion Drive. There are two springs for the feed and two springs for the reversal. Each set gives you double smoothness for ULTRA accurate tapping applications (not possible with this type of tapping head in the past).
- Pre-set Torque Control Permits easy operation of tap brake torque control
- JACOBS RUBBER FLEX COLLETS are standard accessory.

Reversing Type

ATTACHMENT DESIGNATIONS ORDER NO.	FOR TAPS	SUITABLE ADAPTERS SIZE	REC. MAX SPEED	LENGTH COMPENSATION				D DIA	D1 DIA	L	L1	WEIGHT (kgs)	CODE NO.
				COMP A	EXP. B	EXP. C	EXP. E						
VTA7-JT6	M2-M7	FC-10/FC-11	1500RPM	5	3.5	1.5	7.0	52	23	125.5	94.5	1.3	3404-020
VTA12-JT6	M3-M12	FC-20/FC-21	1000RPM	5	4.5	1.5	8.5	73.5	28	169	122	3.1	3404-021
VTA20-M20	M8-M20	FC-30/FC-31	600RPM	5.5	5	2.0	9.0	91	38	190	128	5.7	3404-022

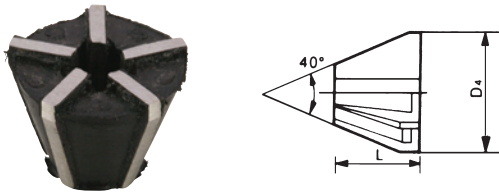

Rubber Flex Collet For VTA Tapper

ORDER NO.	COLLETS CAPACITY	D4	L	CODE NO.
FC-10	Ø 2.5 - Ø 4.5	16	11	3404-030
FC-11	Ø 4.5 - Ø 6.5	16	11	3404-031
FC-20	Ø 4 - Ø 7	21.5	13	3404-032
FC-21	Ø 7 - Ø 10	21.5	13	3404-033
FC-30	Ø 5.36 - Ø 9	26.5	15	3404-034
FC-31	Ø 10.38 - Ø 14	26.5	15	3404-035

CONNECTING ARBOR FOR VTA20-M20	
MT3-M20	3404-036A
MT4-M20	3404-037A

ARBOR EXAMPLE :



please see page C46





Expansible Tapping Holder



Compression Distance 6mm

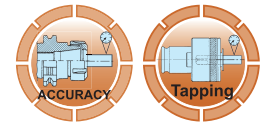
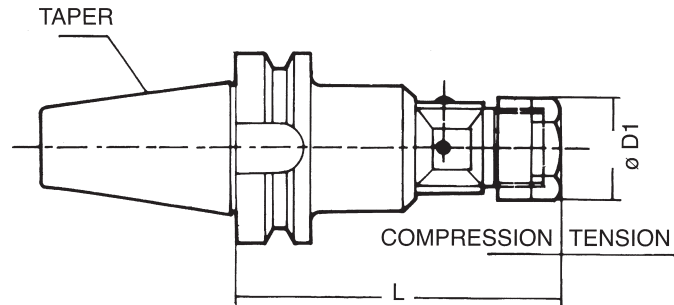

TAPPING HOLDER

HOLDER-BT-TYPE

Unit:mm

ORDER NO.	COLLET	HOLDER (DXL)	L	D ₁	TAPPING RANGE	WEIGHT (KGS)	CODE NO.
VET-271	ER20	BT40 20X100	100	34	M2-M16	2.2	3404-026
VET-272	ER20	BT50 20X95	95	34		4	3404-027
VET-273	ER32	BT40 32X110	110	50	M3-M25	2.4	3404-028
VET-274	ER32	BT50 32X110	110	50		4.5	3404-029



WITH SPANNER

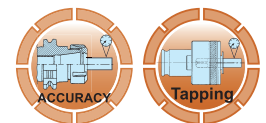
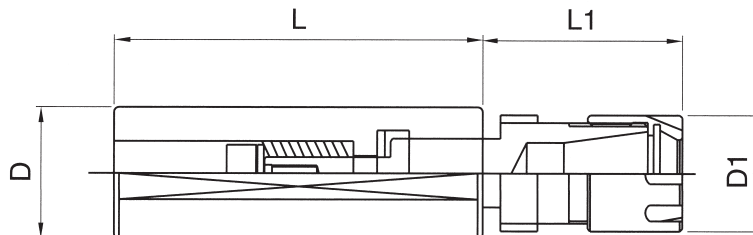

HOLDER-MINI TYPE

Unit:mm

ORDER NO.	COLLET	HOLDER (DXL)	L ₁	D ₁	TAPPING RANGE	WEIGHT (KG)	CODE NO.
VET-260	ER16	ER16M 20X70	35	22	M3-M10 1/8"-3/8"	0.2	3404-036
VET-261	ER16	ER16M 25X70	35	22		0.2	3404-037



Expansible Tapping Holder



- Floating and expansion design will reduce the differential of motor rotary speed and feeding speed so will extend the life of tap.
- Use ER High Spring Collet, you don't need to worry the few size will delay working, so their value is more than any other tapping system.
- Strong Vise clamping function which is controlled by one screw will keep the outlet which have been controlled by ER collet, so it can auto-center and you own the double lock and save in clamping.
- The series. can be fitted with ER20 collet as optional accessory.

STRAIGHT SHANK

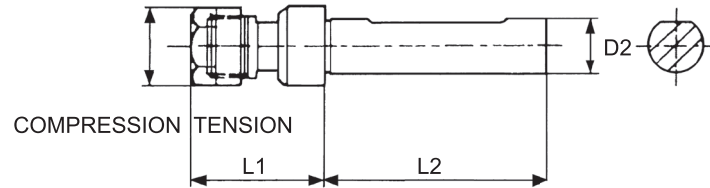

Compression Distance 6mm

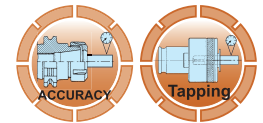

Unit:mm

SINGLE HOLDER

ORDER NO.	COLLET	HOLDER (D ₂ XL ₂)	L ₁	D ₁	TAPPING RANGE	WEIGHT (KG)	CODE NO.
VET-102	ER16	20X80	47	28	M3-M10 (1/8"-3/8")	0.4	3404-041

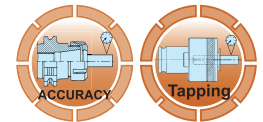
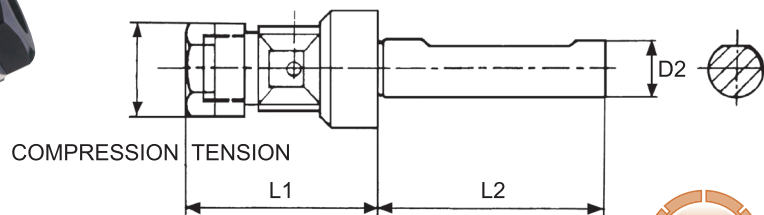
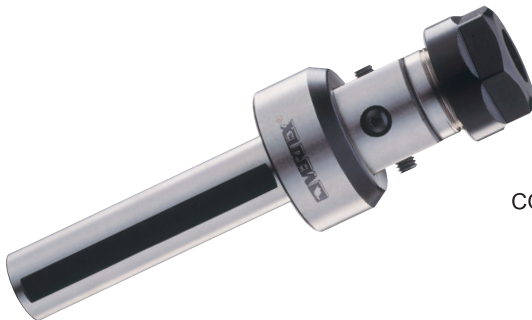

Unit:mm

SINGLE HOLDER

ORDER NO.	COLLET	HOLDER (D ₂ XL ₂)	L ₁	D ₁	TAPPING RANGE	WEIGHT (KG)	CODE NO.
VET-202	ER20	20X80	70	34	M3-M16 (1/8"-5/8")	1	3404-043
VET-252	ER20	25X80	70	34		1.2	3404-044
VET-303	ER32	32X100	90	50	(M3-M25) (1/8"-1")	2	3404-045

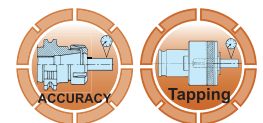

Unit:mm

SETS TYPE

ORDER NO.	COLLET	HOLDER (D ₂ XL ₂)	SET/PCS	WEIGHT (KG)	CODE NO.
VET-105	ER16	20X80	8	1	3404-046
VET-106	ER16	20X80	10	1.1	3404-047
VET-253	ER20	20X80	10	1.6	3404-048
VET-254	ER20	20X80	12	1.7	3404-049



Quick Change Tapping Chuck



European Type

SPECIAL!

**SAFETY !
QUICK !**



TAPPING CHUCKS

QUICK CHANGE TAPPING CHUCKS (with length compensation) MAS-BT-30, 40, 50 Shank / DIN69871A SK-40, 50 / ST-20 , 32 / MT-2 , 3 , 4

- Tension and compression feature allows taps to follow their own thread lead.
- With extreme light compression compression and tension operated by ball cage.



Quick Change Tapping Chucks

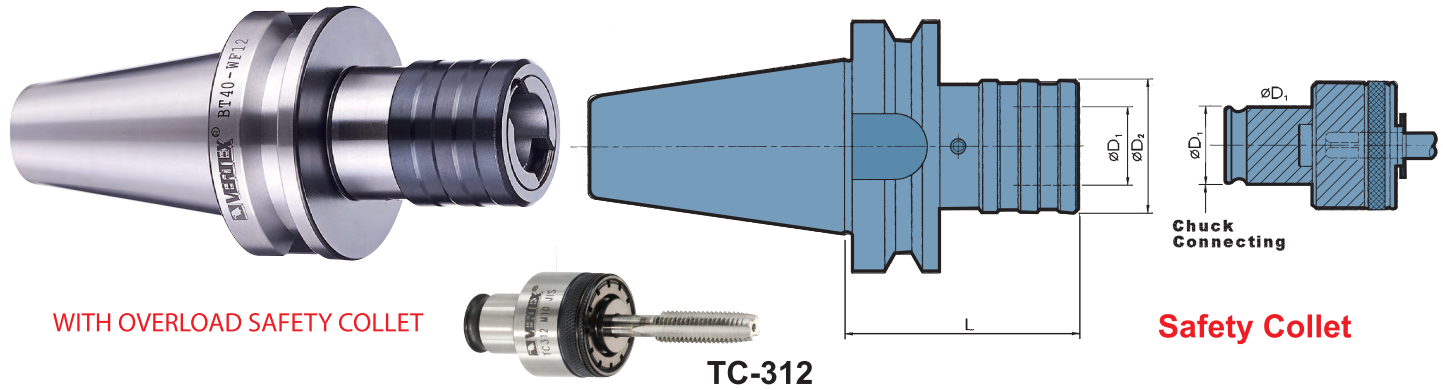

- Tension and compression feature allows taps to follow their own thread lead.
- With extreme light compensation compression and tension operated by ball cage.

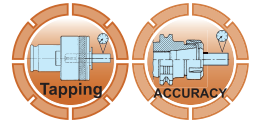

WF-BT30/BT40/SK30/SK40 LENGTH COMPENSATION TYPE

ORDER NO.	Thread Size	L	ØD1 Chuck Connecting DIA.	ØD2	Length Compensation		Tapping Collets	WEIGHT (kg)	CODE NO.
					Compression	Tension			
BT30-WF12	M2-M14	70	Ø19	36	7.5	7.5	TC-312	0.8	3404-050A
BT40-WF12	M2-M14	75	Ø19	36	7.5	7.5	TC-312	1.3	3404-050
SK40-WF12								1.3	3404-051
BT30-WF20	M5-M24	94	Ø31	53	12.5	12.5	TC-820	1.3	3404-052A
BT40-WF20	M5-M24	95	Ø31	53	12.5	12.5	TC-820	1.8	3404-052
SK40-WF20	M5-M24	95	Ø32	53	12.5	12.5	TC-820	1.8	3404-053

※Tapping Collet Reducer Adapter : TC820 / TC312-AD



Quick Change Tapping Chucks

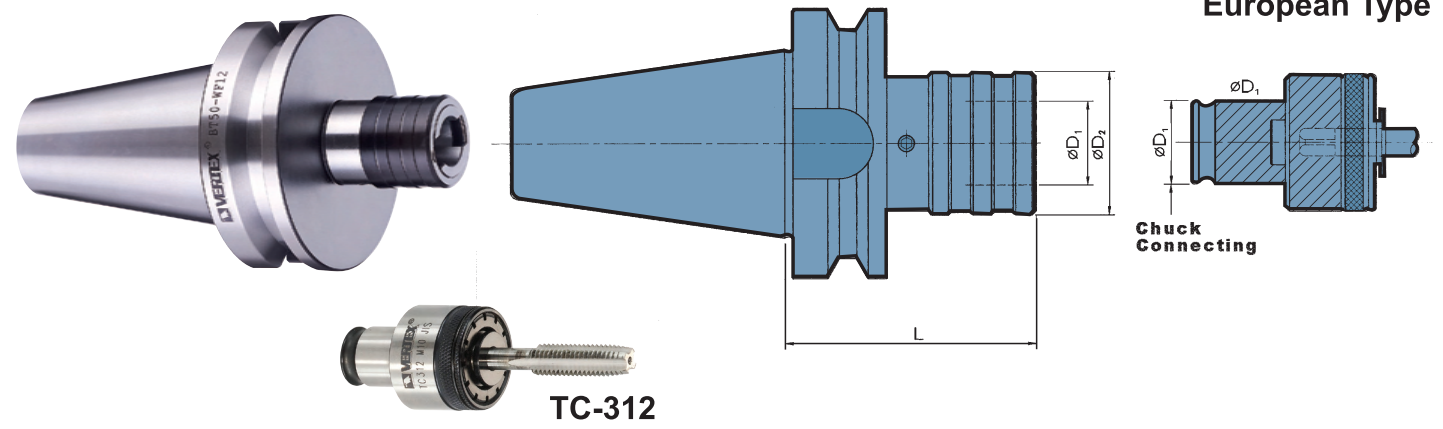

- Tension and compression feature allows taps to follow their own thread lead.
- With extreme light compensation compression and tension operated by ball cage.

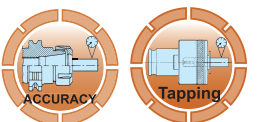

WF-BT50/SK50 LENGTH COMPENSATION TYPE

ORDER NO.	Thread Size	L	ØD1 Chuck Connecting DIA.	ØD2	Length Compensation		Collets	WEIGHT (kg)	CODE NO.
					Compression	Tension			
BT50-WF12	M2-M14	85	Ø19	36	7.5	7.5	TC-312	4	3404-060
SK50-WF12								4	3404-061
BT50-WF20	M5-M24	85	Ø31	53	12.5	12.5	TC-820	4.1	3404-062
SK50-WF20								4.1	3404-063
BT50-WF33	M14-M36	142	Ø48	78	20	20	TC-1433	5.8	3404-064

※Tapping Collet Reducer Adapter : TC820 / TC312-AD TC1433 / TC820-AD



Quick Change Tapping Chucks



**QUICK CHANGE TAPPING CHUCKS (with length compensation)
STRAIGHT SHANK**

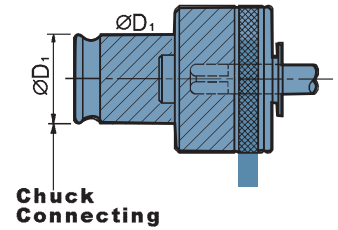
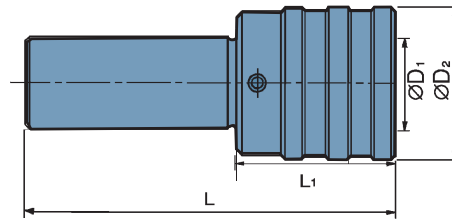

WITH OVERLOAD SAFETY COLLET



TC-312

- Tension and compression feature allows taps to follow their own thread lead.
- With extreme light compensation compression and tension operated by ball cage.

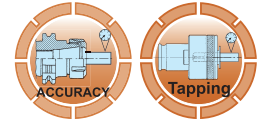

WF-ST LENGTH COMPENSATION TYPE

ORDER NO.	Thread Size	L	L1	ØD1 Chuck Connecting DIA.	ØD2	Length Compensation		Collets	WEIGHT (kg)	CODE NO.
						Compression	Tension			
ST20-WF12	M2-M14	105	40	Ø19	36	7.5	7.5	TC-312	0.4	3404-087
ST32-WF12									0.6	3404-088
ST20-WF20	M5-M24	120	65	Ø31	53	12.5	12.5	TC-820	1	3404-089

※Tapping Collet Reducer Adapter : TC820 / TC312-AD TC1433 / TC820-AD



Quick Change Tapping Chucks

Solid Type

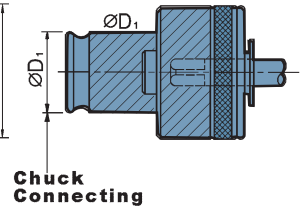
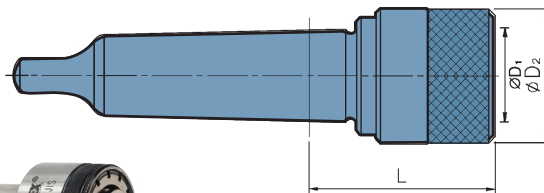

WITH OVERLOAD SAFETY COLLET



TC-312

- Tension and compression feature allows taps to follow their own thread lead.
- With extreme light compensation compression and tension operated by ball cage.

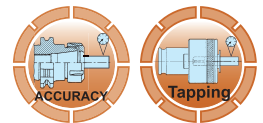

WF-MT LENGTH COMPENSATION TYPE

ORDER NO.	Thread Size	Morse Taper MT	L	ØD1 Chuck Connecting DIA.	ØD2	Length Compensation		Collets	WEIGHT (kg)	CODE NO.
						Compression	Tension			
MT2-WF12	M2-M14	MT2	47.5	Ø19	36	7.5	7.5	TC-312	0.4	3404-123
MT3-WF12		MT3							0.56	3404-123A
MT4-WF12		MT4							0.86	3404-123B
MT2-WF20	M5-M24	MT2	70	Ø31	53	12.5	12.5	TC-820	0.8	3404-124
MT3-WF20		MT3							0.96	3404-124A
MT4-WF20		MT4							1.5	3404-124B
MT4-WF33	M14-M36	MT4	103	Ø48	78	20	15	TC-1433	2.76	3404-125

※Tapping Collet Reducer Adapter : TC820 / TC312-AD TC1433 / TC820-AD



Quick Change Tapping Chucks



QUICK CHANGE TAPPING CHUCKS (with length compensation)

MAS-BT SHANK / DIN69871A SHANK

- Tension and compression feature allows taps to follow their own thread lead.

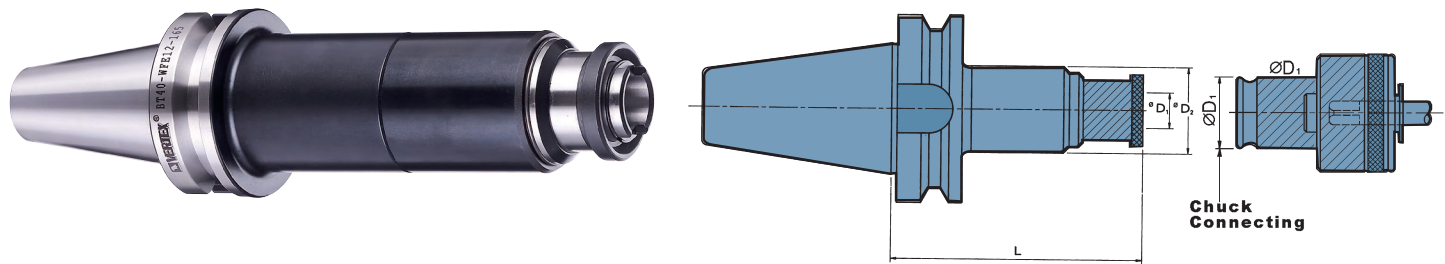

WITH OVERLOAD SAFETY COLLET



TC-312

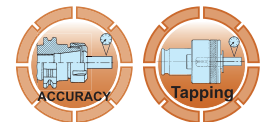

WFE-BT40 LENGTH COMPENSATION TYPE

ORDER NO.	Thread Size	L	$\varnothing D_1$ Chuck Connecting DIA.	$\varnothing D_2$	Length Compensation		Collets	WEIGHT (kg)	CODE NO.
					Compression	Tension			
BT40-WFE12-135	M2-M14	135	$\varnothing 19$	46	15	20	TC-312	1.5	3404-070
BT40-WFE12-165		165						2.4	3404-072

※Tapping Collet Reducer Adapter : TC820 / TC312-AD TC1433 / TC820-AD



Quick Change Tapping Chucks

QUICK CHANGE TAPPING CHUCKS (with length compensation)

MAS-BT SHANK / DIN69871A SHANK

- Tension and compression feature allows taps to follow their own thread lead.

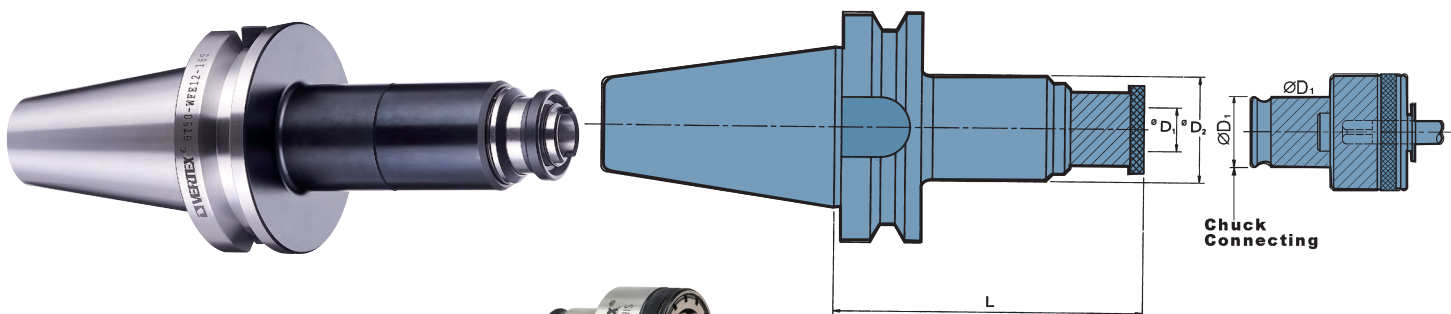

WITH OVERLOAD SAFETY COLLET



TC-312

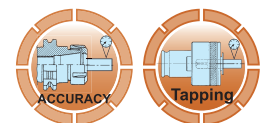

WFE-BT50 LENGTH COMPENSATION TYPE

ORDER NO.	Thread Size	L	$\varnothing D_1$ Chuck Connecting DIA.	$\varnothing D_2$	Length Compensation		Collets	WEIGHT (kg)	CODE NO.
					Compression	Tension			
BT50-WFE12-135	M2-M14	135	$\varnothing 19$	46	15	20	TC-312	4.54	3404-080
BT50-WFE12-165		165						4.94	3404-082
BT50-WFE20-165	M5-M24	165	$\varnothing 31$	58	15	15	TC-820	7	3404-084

※Tapping Collet Reducer Adapter : TC820 / TC312-AD TC1433 / TC820-AD



Quick Change Tapping Chucks



MSA-BT SHANK & DIN 69871A SHANK

Solid Type

- No tension or compensation stroke for use in synchronous tapping (rigid tapping) cycle.

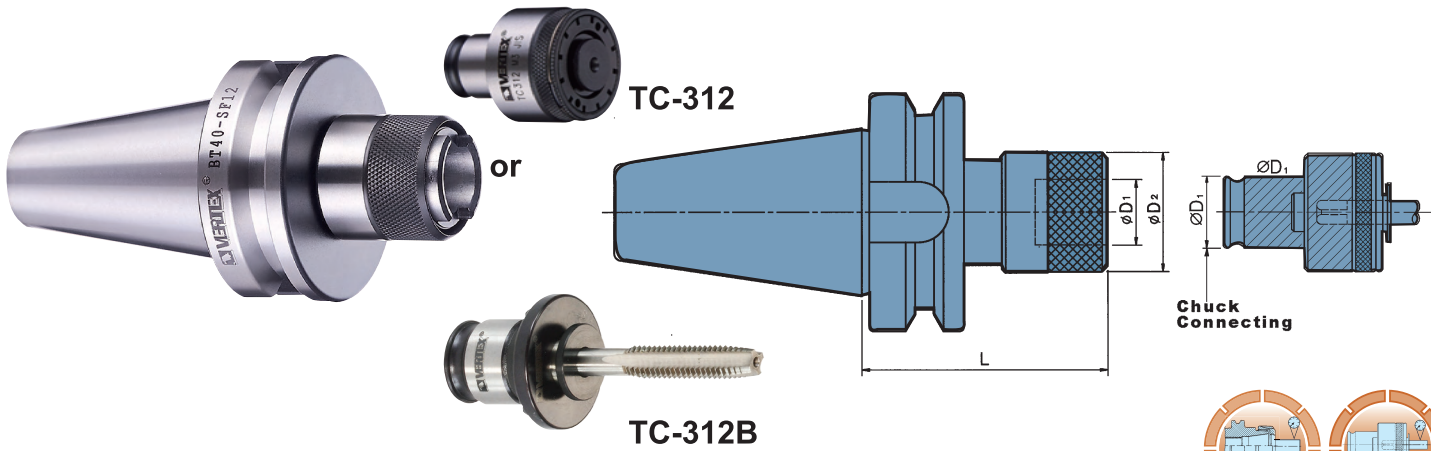

BT40-SF- RIGID TAPPING TYPE , NO LENGTH COMPENSATION

ORDER NO.	Thread Size	L	ØD1 Chuck Connecting DIA.	ØD2	Collets	WEIGHT (kg)	CODE NO.
BT40-SF12	M2-M14	72	Ø19	34	TC-312 TC-312B	1	3404-100
BT40-SF20	M5-M24	91	Ø31	50	TC-820 TC-820B	1.4	3404-102
BT40-SF33	M14-M36	130	Ø48	74	TC-1433 TC-1433B	3.5	3404-104

※Tapping Collet Reducer Adapter : TC820 / TC312-AD TC1433 / TC820-AD



Quick Change Tapping Chucks

MSA-BT SHANK & DIN 69871A SHANK

Solid Type

- No tension or compensation stroke for use in synchronous tapping (rigid tapping) cycle.

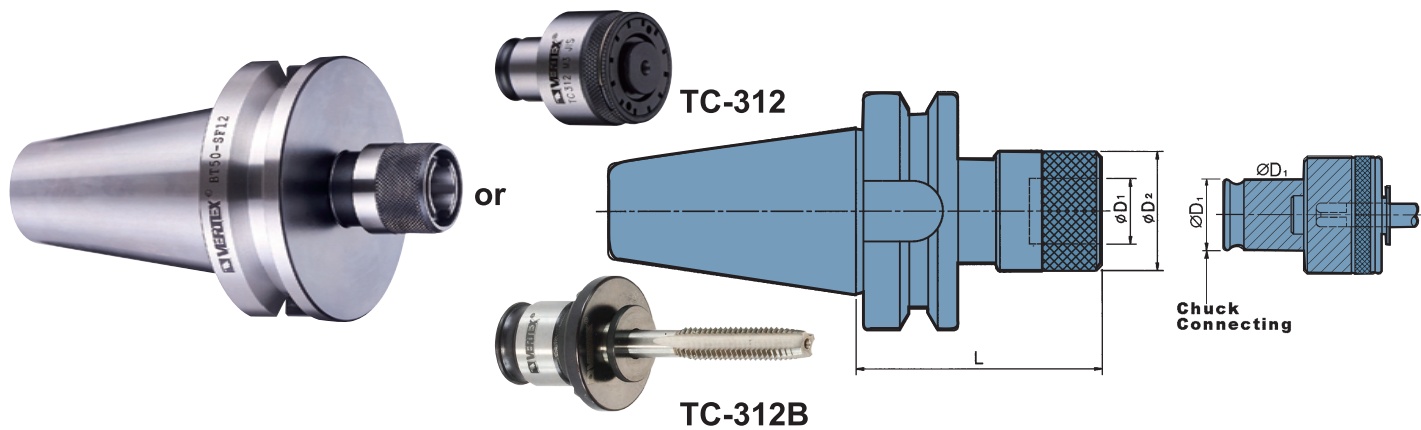

BT50-SF- RIGID TAPPING TYPE, NO LENGTH COMPENSATION

ORDER NO.	Thread Size	L	ØD1 Chuck Connecting DIA.	ØD2	Collets	WEIGHT (kg)	CODE NO.
BT50-SF12	M2-M14	78	Ø19	34	TC-312 TC-312B	3.6	3404-110
BT50-SF20	M5-M24	95	Ø31	50	TC-820 TC-820B	4	3404-112
BT50-SF33	M14-M36	142	Ø48	74	TC-1433 TC-1433B	5.6	3404-116

※Tapping Collet Reducer Adapter : TC820 / TC312-AD TC1433 / TC820-AD



Quick Change Tapping Chucks



QUICK CHANGE TAPPING CHUCKS

Solid Type

MORSE TAPER SHANK

- Tension and compression feature allows taps to follow their own thread lead.
- With extreme light compensation compression and tension operated by ball cage.

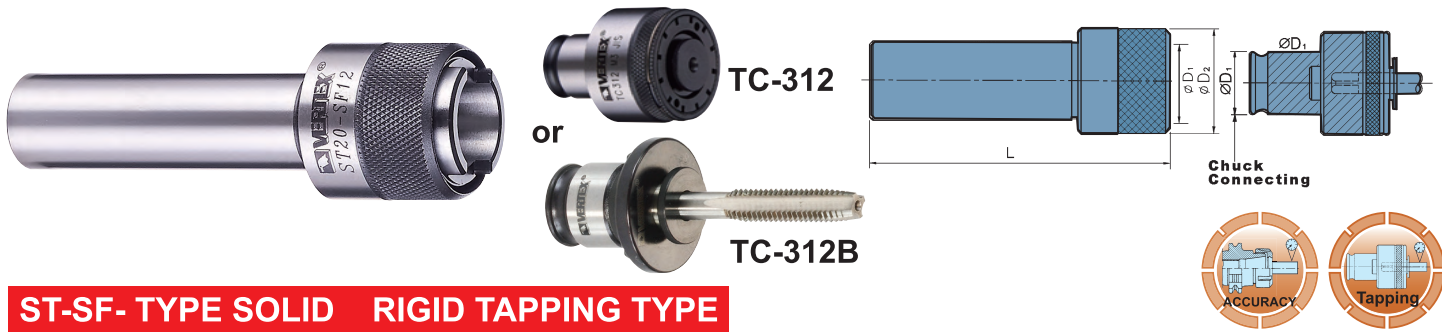

ST-SF- TYPE SOLID RIGID TAPPING TYPE

ORDER NO.	Thread Size	L	L1	ØD1 Chuck Connecting DIA.	ØD2	Collets	WEIGHT (kg)	CODE NO.
ST20-SF12	M2-M14	104	70	Ø19	34	TC-312	0.3	3404-140
ST32-SF12		106		Ø19		TC-312B	0.66	3404-140A
ST20-SF20	M5-M24	105		Ø31	50	TC-820 TC-820B	0.74	3404-141
ST32-SF33	M14-M36	169		Ø48	76	TC-1433 TC-1433B	2.86	3404-142A

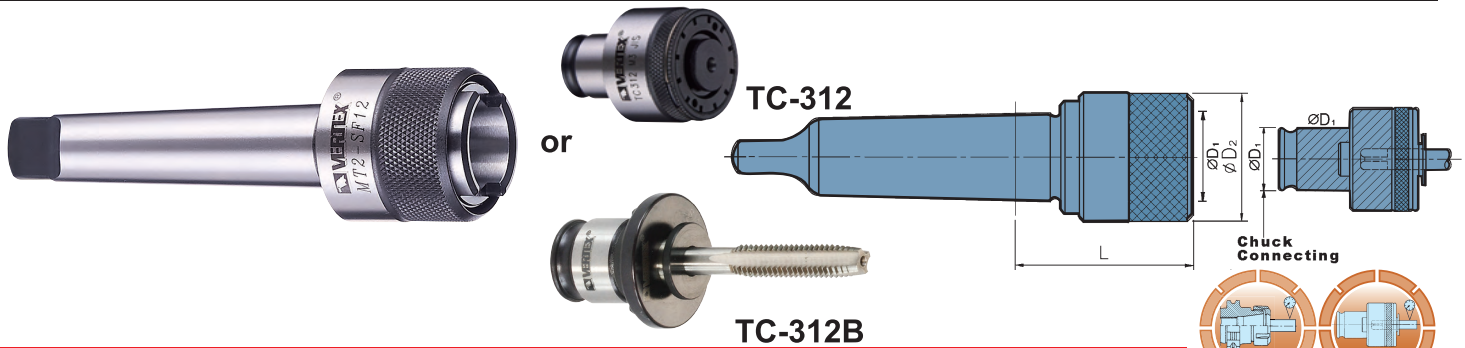

MT-SF- TYPE SOLID RIGID TAPPING TYPE, NO LENGTH COMPENSATION

ORDER NO.	Thread Size	Morse Taper MT	L	ØD1 Chuck Connecting DIA.	ØD2	Collets	WEIGHT (kg)	CODE NO.
MT2-SF12	M2-M14	MT2	45	Ø19	34	TC-312 TC-312B	0.3	3404-120
MT3-SF12		MT3					0.8	3404-120A
MT4-SF12		MT4	0.8				3404-120B	
MT2-SF20	M5-M24	MT2	70	Ø31	50	TC-820 TC-820B	0.6	3404-121A
MT3-SF20		MT3					0.8	3404-121
MT4-SF20		MT4	75				1.18	3404-121B
MT3-SF33	M14-M36	MT3	99	Ø48	74	TC-1433 TC-1433B	0.84	3404-122A
MT4-SF33		MT4	99				2.2	3404-122

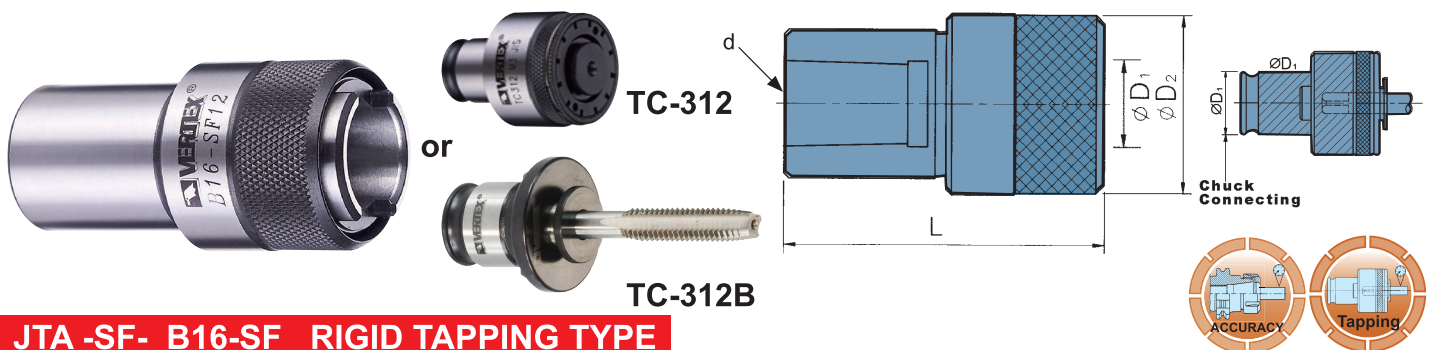

JTA-SF- B16-SF RIGID TAPPING TYPE

ORDER NO.	Thread Size	L	ØD1 Chuck Connecting DIA.	ØD2	d	Collets	WEIGHT (kg)	CODE NO.
JTA6-SF12	M2-M14	66	Ø19	32	JT6	TC-312 TC-312B	0.3	3404-130
B16-SF12					B16		0.22	3404-130A
B12-SF12					B12		0.2	3404-130B

※Tapping Collet Reducer Adapter : TC820 / TC312-AD TC1433 / TC820-AD



Quick Change Tapping Chucks Set



Shank with length compensation

European Type

NEW



- Tension and compression feature allows taps to follow their own thread lead.
- With extreme light compensation compression and tension operated by ball cage.



SET TYPE BT-WF
SHANK WITH 7 PCS/SET OVERLOAD CLUTCH
TAPPING COLLET DIN, ISO & JIS SYSTEMS:
PLEASE SEE PAGE 121.

Collets Size	
TC-312	M3, M4, M5, M6, M8, M10, M12
TC-820	M8, M10, M12, M14, M16, M18, M20

Please inform the collet size when ordering.
Please use following page as reference for collet size.

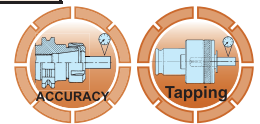

TAPPING CHUCKS

SETS

ORDER NO.	Shank Size	Thread Size	L	ØD1	ØD2	Length Compensation		Collets	PCS/SET	CODE NO.
						Compression	Tension			
VQT-312	BT-30-WF12	M3-M12	70	19	36	7.5	7.5	TC-312	7PCS	3404-190
VQT-320	BT-30-WF20	M8-M20	105	31	53	12.5	12.5	TC-820	7PCS	3404-191
VQT-412	BT-40-WF12	M3-M12	75	19	36	7.5	7.5	TC-312	7PCS	3404-192
VQT-420	BT-40-WF20	M8-M20	95	31	53	12.5	12.5	TC-820	7PCS	3404-193
VQT-512	BT-50-WF12	M3-M12	85	19	36	7.5	7.5	TC-312	7PCS	3404-194
VQT-520	BT-50-WF20	M8-M20	105	31	53	12.5	12.5	TC-820	7PCS	3404-195



Quick Change MT Tapping Chuck Set

With Overload Clutch

NEW



- Tension and compression feature allows taps to follow their own thread lead.
- With extreme light compensation compression and tension operated by ball cage.

SET TYPE MT-SF
SHANK WITH 7 PCS/SET OVERLOAD CLUTCH
TAPPING COLLET DIN, ISO & JIS SYSTEMS:
PLEASE SEE PAGE 121.

Collets Size	
TC-312	M3, M4, M5, M6, M8, M10, M12
TC-820	M8, M10, M12, M14, M16, M18, M20

Please inform the collet size when ordering.
Please use following page as reference for collet size.

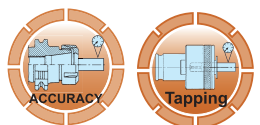

SETS

ORDER NO.	Shank Size	Thread Size	L	ØD2	Collets	PCS/SET	CODE NO.
VQT-712	MT3-SF12	M3-M12	39	32	TC-312	7PCS	3404-196
VQT-812	MT4-SF12	M3-M12	34	32	TC-312	7PCS	3404-197
VQT-720	MT3-SF20	M8-M20	59	50	TC-820	7PCS	3404-198
VQT-820	MT4-SF20	M8-M20	55	50	TC-820	7PCS	3404-199