



1/4" System



1/4" INSIDE DIAMETER







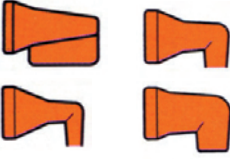













FIG.	ITEM NO.	DESCRIPTION
	V-82020	1/4" Hose Kit 33 CM Length with Fittings: 2-14 CM Segments 1/16", 1/8", 1/4" Nozzles 1/4" & 1/8" Male PT connectors CODE NO.2016-101
	V-82020A	1/4" Hose Kit 33 CM Length with Fittings: 2-14 CM Segments 1/16", 1/8", 1/4" Nozzles 1/4" & 1/8" Male NPT connectors CODE NO.2016-102
	V-82220	1/4" Extenden Element Kit with Element Clamps Includes 4 each of: 1/4" Extended Elements 1/4" Element Clamps CODE NO.2016-103
	V-82021	1/4" Segment pack (2-14CM 20pcs) CODE NO.2016-104-1
	V-82051	1/4" 1524 CM coil CODE NO.2016-104-2
	V-82071	1/4" 2500 Cm coil CODE NO.2016-104-3 Weight : 0.00177kg
	V-62423	1/4" Circle Flow Nozzle Kit Assembled with 15 Side Flow Nozzles 1/4" & 1 End Cap 1/4" CODE NO.2016-105
	V-82221	1/4" Extended Elements, pack of 4 CODE NO.2016-106
	V-82241	1/4" Exdended Elements, pack of 20 CODE NO.2016-107 Weight : 0.00641kg
	V-82222	1/4" Element Clamps, pack of 4 CODE NO.2016-108
	V-82242	1/4" Element Clamps, pack of 20 CODE NO.2016-109 Weight : 0.00265kg
	V-82326	1/4" 90° Nozzle Kit 1 Each: 1/16", 1/8", 1/4" & Spray Bar Nozzles CODE NO.2016-110
	V-82022	1/16" Round Nozzles Pack of 4 CODE NO.2016-111
	V-82042	1/16" Round Nozzles Pack of 50 CODE NO.2016-112 Weight : 0.0016kg
	V-82023	1/8" Round Nozzles Pack of 4 CODE NO.2016-113
	V-82043	1/8" Round Nozzles Pack of 50 CODE NO.2016-114 Weight : 0.00195kg
	V-82024	1/4" Round Nozzles Pack of 4 CODE NO.2016-115
	V-82044	1/4" Round Nozzles Pack of 50 CODE NO.2016-116 Weight : 0.00288kg

FIG.	ITEM NO.	DESCRIPTION
	V-82223	1/16" 90° Nozzles, pack of 4 CODE NO.2016-117
	V-82243	1/16" 90° Nozzles, pack of 20 CODE NO.2016-118 Weight : 0.00156kg
	V-82224	1/8" 90° Nozzles, pack of 4 CODE NO.2016-119
	V-82244	1/8" 90° Nozzles, pack of 20 CODE NO.2016-120 Weight : 0.00183kg
	V-82225	1/4" 90° Nozzles, CODE NO.2016-121
	V-82245	pack of 4 1/4" 90° Nozzles, pack of 20 CODE NO.2016-122 Weight : 0.00236kg
	V-82226	1/4" 90° Spray Bar Nozzles, pack of 2 CODE NO.2016-123
	V-82246	1/4" 90° Spray Bar Nozzles, pack of 20 CODE NO.2016-124 Weight : 0.00285kg
	V-82017	3/8" Flat Nozzles, pack of 2 CODE NO.2016-125
	V-82037	3/8" Flat Nozzles, pack of 20 CODE NO.2016-126 Weight : 0.00202kg
	V-82027	1" Flare Nozzles, pack of 2 CODE NO.2016-127
	V-82047	1" Flare Nozzles, pack of 20 CODE NO.2016-128 Weight : 0.00288kg
	V-82025	1/8" PT Connectors pack of 4 CODE NO.2016-129
	V-82035	1/8" PT Connectors pack of 50 CODE NO.2016-130 Weight : 0.00232kg
	V-82025A	1/8" NPT Connectors pack of 4 CODE NO.2016-131
	V-82035A	1/8" NPT Connectors pack of 50 CODE NO.2016-132 Weight : 0.0023kg
	V-82026	1/4" PT Connectors pack of 4 CODE NO.2016-133
	V-82036	1/4" PT Connectors pack of 50 CODE NO.2016-134 Weight : 0.00259kg
	V-82026A	1/4" NPT Connectors pack of 4 CODE NO.2016-135
	V-82036A	1/4" NPT Connectors pack of 50 CODE NO.2016-136 Weight : 0.00267kg



1/4" System



1/4" INSIDE DIAMETER

FIG.	ITEM NO.	DESCRIPTION
	V-82028	1/4"Y Fitting Pack of 2 CODE NO.2016-137
	V-82038	1/4"Y Fitting Pack of 20 CODE NO.2016-138 Weight : 0.00269kg
	V-82011	1/4"Double Sockets, pack of 4 CODE NO.2016-139
	V-82031	1/4"Double Sockets, pack of 20 CODE NO.2016-140 Weight : 0.00177kg
	V-82012	1/4"Socket to 1/8" NPT, pack of 4 CODE NO.2016-141
	V-82032	1/4"Socket to 1/8" NPTF, pack of 20 CODE NO.2016-142 Weight : 0.00287kg
	V-82013	3/8"SAE Flare Nut Adapters, pack of 4 CODE NO.2016-143
	V-82033	3/8"SAE Flare Nut Adapters, pack of 20(5/8-18 Thread) CODE NO.2016-144 Weight : 0.00397kg
	V-82014	1/4"SAE Flare Nut Adapters, pack of 4 CODE NO.2016-145
	V-82034	1/4"SAE Flare Nut Adapters, pack of 20 (7/16-20 Thread) CODE NO.2016-146 Weight : 0.00167kg
	V-62420	1/4"Elbow Fittings pack of 2 CODE NO.2016-147
	V-62430	1/4"Elbow Fittings pack of 20 CODE NO.2016-148 Weight : 0.00242kg
	V-62426	1/4" T Fitting pack of 2 CODE NO.2016-149
	V-62436	1/4" T Fitting pack of 20 CODE NO.2016-150 Weight : 0.00375kg
	V-62422	1/4" Side Flow Nozzles, pack of 4 CODE NO.2016-151
	V-62442	1/4" Side Flow Nozzles, pack of 20 CODE NO.2016-152 Weight : 0.00275kg
	V-62424	1/4"End Caps, pack of 4 CODE NO.2016-153-1
	V-62444	1/4"End caps, pack of 20 CODE NO.2016-153-2 Weight : 0.00191kg
	V-82228	1/4"Swivel Nozzle 40, pack of 2 CODE NO.2016-154
	V-82248	1/4"Swivel Nozzle 40, pack of 20 CODE NO.2016-155 Weight : 0.00875kg

FIG.	ITEM NO.	DESCRIPTION
	V-82229	1/4"Swivel Nozzle 60, pack of 2 CODE NO.2016-156
	V-82249	1/4"Swivel Nozzle 60, pack of 20 CODE NO.2016-157 Weight : 0.00845kg
	V-82721	1/4"NPT Male Hose Nipple Valves pack of 2 CODE NO.2016-158
	V-82731	1/4"NPT Male Hose Nipple Valves pack of 10 CODE NO.2016-159 Weight : 0.0078kg
	V-82722	1/4"Connection Valves, pack of 2 CODE NO.2016-162
	V-82732	1/4"Connection Valves, pack of 10 CODE NO.2016-163 Weight : 0.00693kg
	V-82522	Acid Resistant 1/4"Connection Valves, pack of 2 CODE NO.2016-164
	V-82532	1/4"Connection Valves, pack of 10 CODE NO.2016-165 Weight : 0.00702kg
	V-82723	1/4"Male PT Valves, pack of 2 CODE NO.2016-166
	V-82733	1/4"Male PT Valves, pack of 10 CODE NO.2016-167 Weight : 0.0076kg
	V-82523	Acid Resistant 1/4"Male NPT Valves, pack of 2 CODE NO.2016-168
	V-82533	1/4"Male NPT Valves, pack of 10 CODE NO.2016-169 Weight : 0.00774kg
	V-82724	1/4"Female PT Valves, pack of 2 CODE NO.2016-170
	V-82744	1/4"Female PT Valves, pack of 10 CODE NO.2016-171 Weight : 0.00809kg
	V-82524	Acid Resistant 1/4"Female NPT Valves, pack of 2 CODE NO.2016-172
	V-82534	1/4"Female NPT Valves, pack of 10 CODE NO.2016-173 Weight : 0.00836kg
	V-82725	1/4"Connection Check Valves,pack of 2 CODE NO.2016-174
	V-82745	1/4"Connection Check Valves,pack of 10 CODE NO.2016-175 Weight : 0.00562kg
	V-52400	Modular Manifold System 1/4" 1/4"Elbow Fitting-1 pcs 1/4"Manifold Bracket-1 pcs 1/4"T Fittings-3 pcs 1/4"Mounting screw-3 pcs CODE NO.2016-176 Weight : 0.0322kg
	V-52410	1/4"Main Flow Control Manifold System 1/4"Modular Manifold-1 pcs 1/4"Connection Valves-5 pcs CODE NO.2016-177 Weight : 0.0675kg
	V-52416	1/4"Manifold Brackets pack of 2 CODE NO.2016-178 Weight : 0.00973kg
	V-26171	1/4"Hose Assembly pliers CODE NO.2016-179

COOLANT HOSE



1/2" System



1/2" INSIDE DIAMETER

FIG.	ITEM NO.	DESCRIPTION	FIG.	ITEM NO.	DESCRIPTION	FIG.	ITEM NO.	DESCRIPTION
	V-84040	1/2" Hose Kit 33 CM Length with Fittings: 2-14 CM Segments 1/4", 3/8", 1/2" Nozzles 3/8", 1/2" Male PT connectors CODE NO. 2016-201		V-84445	1/2"90° Nozzles, pack of 4 CODE NO. 2016-221		V-64626	1/2" T Fittings, pack of 2 CODE NO. 2016-251
	V-84040A	1/2" Hose Kit 33 CM Length with Fittings: 2-14 CM Segments 1/4", 3/8", Nozzles 3/8", 1/2" Male NPT connectors CODE NO. 2016-202		V-84465	1/2"90° Nozzles, pack of 20 CODE NO. 2016-222 Weight : 0.00552kg		V-64646	1/2" T Fittings, pack of 20 CODE NO. 2016-252 Weight : 0.0097kg
	V-84440	1/2" Extended Element Kit with Element Clamps Includes 4 each of: 1/2" Extended Elements 1/2" Element Clamps CODE NO. 2016-203		V-84446	1/2"90° Spray Bar, pack of 2 CODE NO. 2016-223		V-64622	1/2" Side Flow Nozzles, pack of 4 CODE NO. 2016-253
	V-84041	Segment pack (2-14 CM 12pcs) CODE NO. 2016-204		V-84466	1/2"90° Spray Bar, pack of 20 CODE NO. 2016-224 Weight : 0.01033kg		V-64642	1/2" Side Flow Nozzles, pack of 20 CODE NO. 2016-254 Weight : 0.0078kg
	V-84081	1/2" 1524 CM coil CODE NO. 2016-205		V-84047	1 1/4" Flare Nozzles, pack of 2 CODE NO. 2016-225		V-64624	1/2" End caps, pack of 4 CODE NO. 2016-255
	V-84091	1/2" 2500 CM coil CODE NO. 2016-206 Weight : 0.00555kg		V-84067	1 1/4" Flare Nozzles, pack of 20 CODE NO. 2016-226 Weight : 0.00696kg		V-64644	1/2" End caps, pack of 20 CODE NO. 2016-256 Weight : 0.00466kg
	V-64643	1/2" Circle Flow Nozzle Kit Assembled with 15 Side Flow Nozzles 1/2" & 1 End Cap 1/2" CODE NO. 2016-207		V-84050	1 3/4" Flare Nozzles, pack of 2 CODE NO. 2016-227		V-84722	1/2" connection Valves, pack of 2 CODE NO. 2016-257
	V-84441	1/2" Extended Elements, pack of 4 CODE NO. 2016-208		V-84070	1 3/4" Flare Nozzles, pack of 20 CODE NO. 2016-228 Weight : 0.0088kg		V-84742	1/2" connection Valves, pack of 10 CODE NO. 2016-258 Weight : 0.02201kg
	V-84461	1/2" Extended Elements, pack of 20 CODE NO. 2016-209 Weight : 0.01186kg		V-84052	2 1/2" Flare Nozzles, pack of 2 CODE NO. 2016-229		V-84522	Acid Resistant 1/2" connection Valves, pack of 2 CODE NO. 2016-259
	V-84346	90° Nozzle Kit 1 Each: 1/4", 3/8", 1/2" & Spray Bar Nozzles CODE NO. 2016-210		V-84072	2 1/2" Flare Nozzles, pack of 20 CODE NO. 2016-230 Weight : 0.00922kg		V-84542	1/2" connection Valves, pack of 10 CODE NO. 2016-260 Weight : 0.02227kg
	V-84044	1/4" Round Nozzles, pack of 4 CODE NO. 2016-211		V-84046	3/8" PT Connectors pack of 4 CODE NO. 2016-231		V-84723	1/2" Male PT Valves, pack of 2 CODE NO. 2016-261
	V-84064	1/4" Round Nozzles, pack of 50 CODE NO. 2016-212 Weight : 0.00339kg		V-84066	3/8" PT Connectors pack of 50 CODE NO. 2016-232 Weight : 0.0063kg		V-84743	1/2" Male PT Valves, pack of 10 CODE NO. 2016-262 Weight : 0.02287kg
	V-84042	3/8" Round Nozzles, pack of 4 CODE NO. 2016-213		V-84046A	3/8" NPT Connectors pack of 4 CODE NO. 2016-233		V-84523	Acid Resistant 1/2" Male NPT Valves, pack of 2 CODE NO. 2016-263
	V-84062	3/8" Round Nozzles, pack of 50 CODE NO. 2016-214 Weight : 0.0435kg		V-84066A	3/8" NPT Connectors pack of 50 CODE NO. 2016-234 Weight : 0.00602kg		V-84543	1/2" Male NPT Valves, pack of 10 CODE NO. 2016-264 Weight : 0.02308kg
	V-84043	1/2" Round Nozzles, pack of 4 CODE NO. 2016-215		V-84045	1/2" PT Connectors pack of 4 CODE NO. 2016-235		V-84724	1/2" Female PT Valves, pack of 2 CODE NO. 2016-265
	V-84063	1/2" Round Nozzles, pack of 50 CODE NO. 2016-216 Weight : 0.0597kg		V-84065	1/2" PT Connectors pack of 50 CODE NO. 2016-236 Weight : 0.00732kg		V-84744	1/2" Female PT Valves, pack of 10 CODE NO. 2016-266 Weight : 0.02348kg
	V-84443	1/4"90° Nozzles, pack of 4 CODE NO. 2016-217		V-84048	1/2" Y Fittings pack of 2 CODE NO. 2016-239		V-84725	1/2" connection Chuck Valves, pack of 2 CODE NO. 2016-269
	V-84463	1/4" 90° Nozzles, pack of 20 CODE NO. 2016-218 Weight : 0.0053kg		V-84068	1/2" Y Fittings pack of 20 CODE NO. 2016-240 Weight : 0.0108kg		V-84745	1/2" connection Chuck Valves, pack of 10 CODE NO. 2016-270 Weight : 0.00878kg
	V-84444	3/8"90° Nozzles, pack of 4 CODE NO. 2016-219		V-84049	1/2" to 1/4" Y Reducers, pack of 2 CODE NO. 2016-241		V-54400	Modular Manifold System 1/2" 1/2"-Elbow Fitting-1 pcs 1/2"-Manifold Bracket- 1 pcs 1/2"-T Fittings-3 pcs 1/2"-Mounting screws- 3 pcs CODE NO. 2016-271 Weight : 0.0562kg
	V-84464	3/8" 90° Nozzles, pack of 20 CODE NO. 2016-220 Weight : 0.00566kg		V-84069	1/2" to 1/4" Y Reducers, pack of 20 CODE NO. 2016-242 Weight : 0.00608kg		V-54410	Main Flow Control Manifold System 1/2" 1-Modular Manifold 1/2" 5-Connection Valves 1/2" CODE NO. 2016-272 Weight : 0.16625kg
	V-84444	3/8"90° Nozzles, pack of 4 CODE NO. 2016-219		V-84011	1/4" SAE Flare Nut Adapters, pack of 4 CODE NO. 2016-247		V-54416	1/2" Manifold Brackets of 2 CODE NO. 2016-273 Weight : 0.01148kg
	V-84464	3/8" 90° Nozzles, pack of 20 CODE NO. 2016-220 Weight : 0.00566kg		V-84031	1/2" Double Sockets, pack of 4 CODE NO. 2016-245		V-26172	1/2" Hose Assembly pliers CODE NO. 2016-274
	V-84444	3/8"90° Nozzles, pack of 4 CODE NO. 2016-219		V-84033	1/4" SAE Flare Nut Adapters, pack of 20 (5/8-18 Thread) CODE NO. 2016-248 Weight : 0.00516kg			
	V-84464	3/8" 90° Nozzles, pack of 20 CODE NO. 2016-220 Weight : 0.00566kg		V-84013	1/2" Double Sockets, pack of 20 CODE NO. 2016-246 Weight : 0.00452kg			
	V-84444	3/8"90° Nozzles, pack of 4 CODE NO. 2016-219		V-84033	1/4" SAE Flare Nut Adapters, pack of 20 (5/8-18 Thread) CODE NO. 2016-248 Weight : 0.00516kg			
	V-84464	3/8" 90° Nozzles, pack of 20 CODE NO. 2016-220 Weight : 0.00566kg		V-64620	1/2" Elbow Fittings, pack of 2 CODE NO. 2016-249			
	V-84464	3/8" 90° Nozzles, pack of 20 CODE NO. 2016-220 Weight : 0.00566kg		V-64640	1/2" Elbow Fittings, pack of 20 CODE NO. 2016-250 Weight : 0.00666kg			



3/8" System



3/8" INSIDE DIAMETER

FIG. ITEM NO. DESCRIPTION







	V-83030	3/8" Hose Kit 8 pcs of 3/8" Segment - 2 sets 3/8" Nozzles 3/8" Male PT connectors CODE NO.2016-275
	V-83030A	3/8" Hose Kit 8 pcs of 3/8" Segment - 2 sets 3/8" Nozzles 1 3/8" Male NPT connectors CODE NO.2016-276
	V-83430	3/8" Hose Kit 8 pcs of 3/8" Segment - 2 pcs 1/4", 3/8", 1/2" Nozzles 3/8" & 1/2" Male PT connectors CODE NO.2016-277
	V-83430A	3/8" Hose Kit 8 pcs of 3/8" Segment - 2 pcs 1/4", 3/8", 1/2" Nozzles 3/8" & 1/2" Male NPT connectors CODE NO.2016-278
	V-83031	3/8" Segment pack (2-14.5CM 8pcs) CODE NO.2016-279
	V-83051	3/8" 762 CM coil CODE NO.2016-280
	V-83091	3/8" 1524 CM coil Weight: 2.8kgs CODE NO.2016-281
	V-83032	1/4" Round Nozzles, pack of 4 CODE NO.2016-282
	V-83052	1/4" Round Nozzles, pack of 50 CODE NO.2016-283

FIG. ITEM NO. DESCRIPTION















	V-83033	3/8" Round Nozzles, pack of 4 CODE NO.2016-284
	V-83053	3/8" Round Nozzles, pack of 50 Wight: 197.2g CODE NO.2016-285
	V-83034	1/2" Round Nozzles, pack of 4 CODE NO.2016-286
	V-83054	1/2" Round Nozzles, pack of 50 CODE NO.2016-287
	V-83026	1/4" PT Connector, pack of 4 CODE NO.2016-288
	V-83046	1/4" PT Connector, pack of 50 CODE NO.2016-289
	V-83035	3/8" PT Connector, pack of 4 CODE NO.2016-290
	V-83055	3/8" PT Connector, pack of 50 CODE NO.2016-291
	V-83035A	3/8" NPT Connector, pack of 4 CODE NO.2016-292
	V-83055A	3/8" NPT Connector, pack of 50 CODE NO.2016-293
	V-83036	1/2" PT Connector, pack of 4 CODE NO.2016-294
	V-83056	1/2" PT Connector, pack of 50 CODE NO.2016-295
	V-83036A	1/2" NPT Connector, pack of 4 CODE NO.2016-296
	V-83056A	1/2" NPT Connector, pack of 50 CODE NO.2016-297

FIG. ITEM NO. DESCRIPTION

	V-83037	1 1/4" Flare Nozzles, pack of 2 CODE NO.2016-298
	V-83057	1 1/4" Flare Nozzles, pack of 20 CODE NO.2016-299
	V-83058	3/8" Y Fitting, pack of 20 CODE NO.2016-300
	V-83723	3/8" Male PT Valve, pack of 2 CODE NO.2016-302
	V-83743	3/8" Male PT Valve, pack of 10 Wight: 127g CODE NO.2016-303
	V-83723A	3/8" Male NPT Valve, pack of 2 CODE NO.2016-304
	V-83743A	3/8" Male NPT Valve, pack of 10 CODE NO.2016-305
	V-83724	3/8" Female PT Valve, pack of 2 CODE NO.2016-306
	V-83744	3/8" Female PT Valve, pack of 10 CODE NO.2016-307
	V-83724A	3/8" Female NPT Valve, pack of 2 CODE NO.2016-308
	V-83744A	3/8" Female NPT Valve, pack of 10 CODE NO.2016-309
	V-26176	3/8" Hose Assembly pliers CODE NO.2016-310



3/4" System

FIG. ITEM NO. DESCRIPTION

























	V-66620	3/4" Elbow Fitting, pack of 2 CODE NO.2016-380
	V-66640	3/4" Elbow Fitting, pack of 20 CODE NO.2016-381
	V-86060	3/4" Hose Kit 6 pcs of 3/4" Segment-2 sets 5/8" & 3/4" Nozzles 3/4" Male PT Connector CODE NO.2016-400
	V-86060A	3/4" Hose Kit 6 pcs of 3/4" Segment-2 sets 5/8" & 3/4" Nozzles 3/4" Male PT Connector CODE NO.2016-401
	V-86061	3/4" Segment Pack (2-15 CM 6pcs) CODE NO.2016-402
	V-86081	3/4" 1524 CM Coil CODE NO.2016-403
	V-86091	3/4" 2500 CM Coil CODE NO.2016-404
	V-86063	5/8" Round Nozzle, pack of 4 CODE NO.2016-405
	V-86073	5/8" Round Nozzle, pack of 50 CODE NO.2016-406
	V-86062	3/4" Round Nozzle, pack of 4 CODE NO.2016-407
	V-86072	3/4" Round Nozzle, pack of 50 CODE NO.2016-408
	V-86064	3/4" PT Connector, pack of 4 CODE NO.2016-409
	V-86074	3/4" PT Nozzle, pack of 50 CODE NO.2016-410

FIG. ITEM NO. DESCRIPTION

	V-86064A	3/4" NPT Connector, pack of 4 CODE NO.2016-411
	V-86074A	3/4" NPT Nozzle, pack of 50 CODE NO.2016-412
	V-86021	3/4" Fixed Mount, pack of 2 CODE NO.2016-413
	V-86022	3/4" Magnetic Base, pack of 1 CODE NO.2016-414
	V-86023	Shield Mounting Elbow, pack of 2 CODE NO.2016-415
	V-86067	3" Flare Nozzle, pack of 2 CODE NO.2016-416
	V-86077	3" Flare Nozzle, pack of 20 CODE NO.2016-417
	V-86068	3/4" Y Fitting, pack of 2 CODE NO.2016-418
	V-86078	3/4" Y Fitting, pack of 20 CODE NO.2016-419
	V-86069	3/4" to 1/2" Y Reducer, pack of 2 CODE NO.2016-420
	V-86079	3/4" to 1/2" Y Reducer, pack of 20 CODE NO.2016-421
	V-86051	3/4" to 1/2" Adapter, pack of 2 CODE NO.2016-422
	V-86071	3/4" to 1/2" Adapter, pack of 20 CODE NO.2016-423
	V-86011	3/4" Double Socket, pack of 4 CODE NO.2016-424
	V-86031	3/4" Double Socket, pack of 20 CODE NO.2016-425

FIG. ITEM NO. DESCRIPTION

	V-86722	3/4" Connection Valve, pack of 2 CODE NO.2016-409
	V-86742	3/4" Connection Valve, pack of 10 CODE NO.2016-430
	V-86723	3/4" Male PT Valve, pack of 2 CODE NO.2016-431
	V-86743	3/4" Male PT Valve, pack of 10 CODE NO.2016-432
	V-86723A	3/4" Male NPT Valve, pack of 2 CODE NO.2016-433
	V-86743A	3/4" Male NPT Valve, pack of 10 CODE NO.2016-434
	V-86724	3/4" Female PT Valve, pack of 2 CODE NO.2016-435
	V-86744	3/4" Female PT Valve, pack of 10 CODE NO.2016-436
	V-86724A	3/4" Female NPT Valve, pack of 2 CODE NO.2016-437
	V-86744A	3/4" Female NPT Valve, pack of 10 CODE NO.2016-438
	V-26177	3/4" Hose Assembly Pliers CODE NO.2016-426
	V-86744	3/4" Female PT Valve, pack of 10 CODE NO.2016-427
	V-86744A	3/4" Female NPT Valve, pack of 10 CODE NO.2016-428

COOLANT HOSE



Paper Filter



FEATURES

- Applicable to both ferrous and non-ferrous metals.
- Filtration effect depends on paper accuracy.
Use 50μ, 30μ, or 15μ.
- Not suitable for heavy machining for the sake of paper consumption.
- To save filtration material, use magnetic filter for rough filtration.
- Standard accessory: one roll of paper.
- ※ Guaranteed for 3 months.

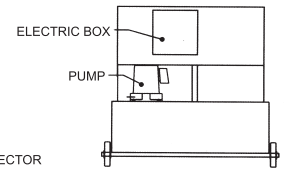
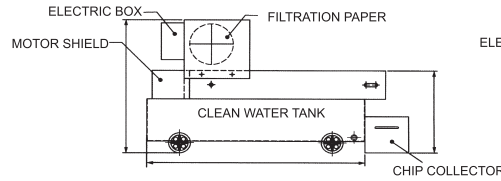
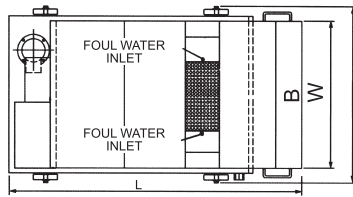

ORDER NO.	DISPOSAL CAPACITY ℓ / min	WATER TANK CAPACITY	L	A	B	C	W	H	PUMP		PAPER MOTOR	PAPER	REMARKS	N.W (kgs)	GW (kgs)	CODE NO.
									HP	OUTLET						
PF-20	20	100 ℓ	1050	850	600	400	720	610	1/8	PF1/2"	25W	W:500MM L:90M	wheels attached	95	120	2020-001
PF-40	40	120 ℓ	1200	1000	600	400	720	660	1/8	PF1/2"	25W			130	150	2020-002
PF-60	60	140 ℓ	1350	1150	600	400	720	660	1/8	PF1/2"	25W			140	170	2020-003
PF-80	80	160 ℓ	1500	1300	600	400	720	660	1/4	PF3/4"	25W			170	190	2020-004
PF-120	120	210 ℓ	1500	1300	800	400	920	740	1/2	PF3/4"	40W			185	210	2020-005
PF-160	160	260 ℓ	1800	1600	800	400	920	740	1/2	PF3/4"	40W	W:700MM L:90M	250	280	2020-006	



Magnetic Separator

FEATURES

- Suitable in heavy machining for ferrous metal.
- No filtration-material consumption.
- Most economic in purchase & utilization cost.
- Able to serve rough filtration in other filtration process.
- Please notify volta & phase, when you ordering.
- ※ Guaranteed for 3 months.

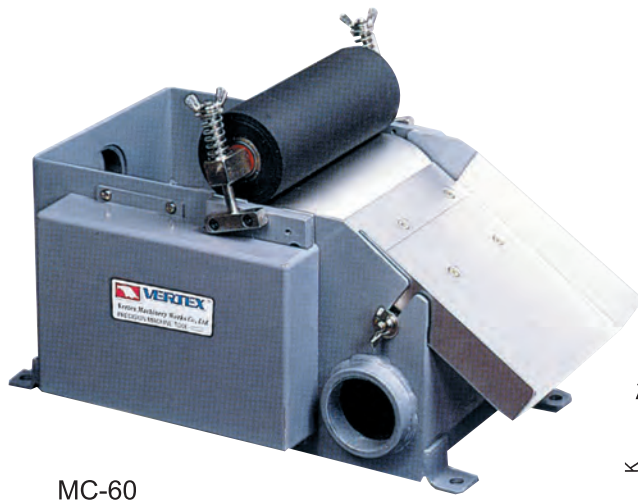

MC-60

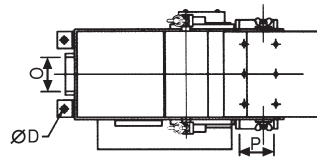

MC-20~160

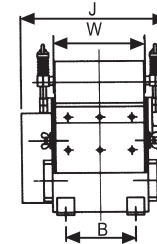
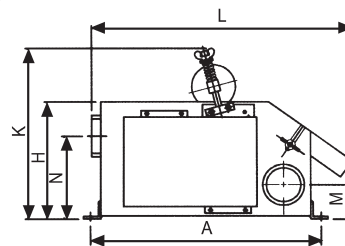

Standard accessories

- a. Chip collector 1pc
- b. plugs 2pc
- c. Elbow 1pc
- d. Steel tubes 3pc

ORDER NO.	DISPOSAL CAPACITY ℓ / min	L	W	H	M	N	A	B	D	J	K	INLET O	OUTLET P	MOTOR	N.W (kgs)	GW (kgs)	CODE NO.
MC-20	20	464	130	205	65	145	398	100	11	230	300	PF1 1/2"	PF1 1/2"	220V3Ø,25W	18	20	2020-010
MC-40	40	464	150	205	65	145	398	120	11	250	300	PF2"	PF2"	220V3Ø,25W	20	23	2020-011
MC-60	60	464	206	205	60	150	398	176	11	306	300	PF2"	PF2"	220V3Ø,25W	25	28	2020-012
MC-80	80	464	242	205	60	150	398	212	11	342	300	PF2"	PF1 1/2"	220V3Ø,25W	25	26.8	2020-013
MC-120	120	530	270	245	68	185	456	230	11	380	345	PF1 1/2"	PF3"	220V3Ø,40W	50	65	2020-014
MC-160	160	530	354	245	68	185	456	314	11	464	345	PF3"	PF3"	220V3Ø,40W	60	75	2020-015

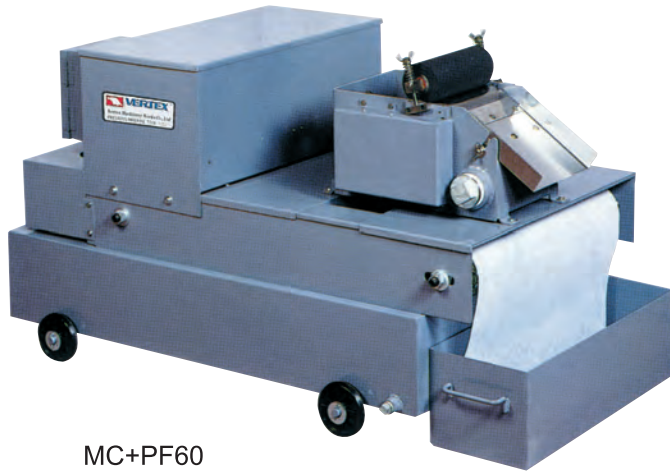

MC+PF60

APPLICABLE TO THE FOLLOWING WORKING MACHINES

- Plane grinding machine.
- Fine-grinding machine.
- Honing machine.
- Deep-hole drill.
- Internal/exterless cylinder grinder.
- Centerless grinder.
- Please specify the power voltage in your order list.
- Specifications are subject to change without notice.
- Please notify volta & phase, when you ordering.

※Guaranteed for 3 months.

FEATURES

- Applicable to both ferrous and non-ferrous metals.
- Filtration effect depends on paper accuracy.
Use 50 μ ,30 μ ,or 15 μ .
- Rough filtration for chip in coolant with magnet and then fine filtration for impurities with paper will save the paper and upgrade filtration accuracy

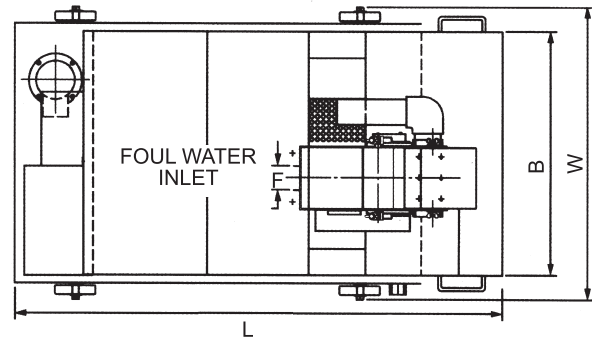

DIMENSION DIAGRAM

- Standard accessory:one roll paper 30 μ

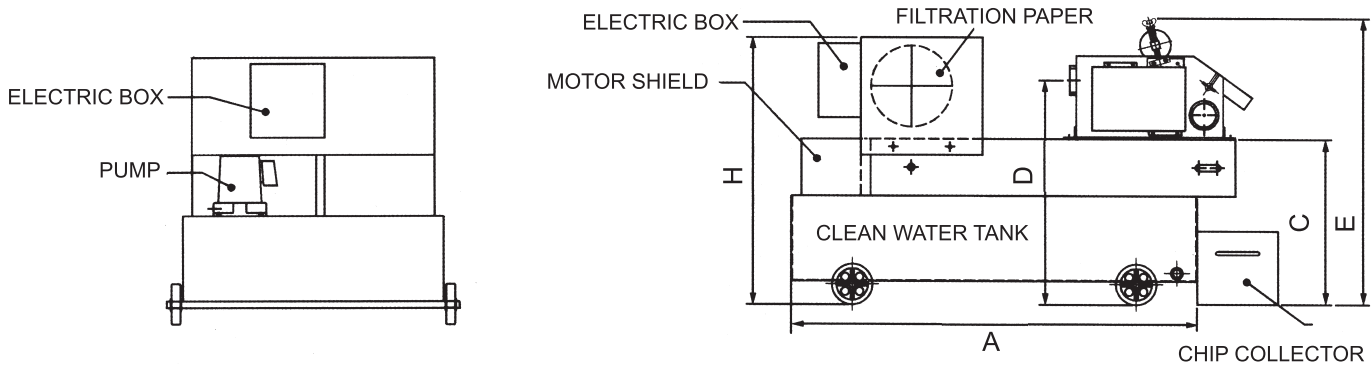

MAGNETIC SEPARATOR & PAPER FILTER SPECIFICATIONS

ORDER NO.	DISPOSAL CAPACITY ℓ / min	WATER TANK CAPACITY	L	A	B	C	D	E	F	H	W	PUMP		PAPER MOTOR	PAPER	REMARKS	N.W (kgs)	GW (kgs)	CODE NO.
												HP	OUTLET						
MC+PF-20	20	100 ℓ	1050	850	600	400	550	655	PF1 $\frac{1}{2}$ "	610	720	$\frac{1}{8}$	PF $\frac{1}{2}$ "	25W			115	140	2020-020
MC+PF-40	40	120 ℓ	1200	1000	600	400	550	705	PF2"	660	720	$\frac{1}{8}$	PF $\frac{1}{2}$ "	25W	W:500MM L:90MM	wheels	150	175	2020-021
MC+PF-60	60	140 ℓ	1350	1150	600	400	555	705	PF2"	660	720	$\frac{1}{8}$	PF $\frac{1}{2}$ "	25W			165	200	2020-022
MC+PF-80	80	160 ℓ	1500	1300	600	400	555	705	PF2"	660	720	$\frac{1}{4}$	PF $\frac{3}{4}$ "	25W			190	225	2020-023
MC+PF-120	120	210 ℓ	1500	1300	800	400	590	750	PF2 $\frac{1}{2}$ "	740	920	$\frac{1}{2}$	PF $\frac{3}{4}$ "	40W	W:700MM L:90MM		235	275	2020-024
MC+PF-160	180	260 ℓ	1800	1600	800	400	605	750	PF3"	740	920	$\frac{1}{2}$	PF $\frac{3}{4}$ "	40W		290	335	2020-025	
MC+PF-240	240	440 ℓ	1550	1350	1060	430	640	915	PF3"	740	1330	1	PF1"	60W		W:1000MM L:90MM	no wheels		



Coolant Tank



Dust Collector

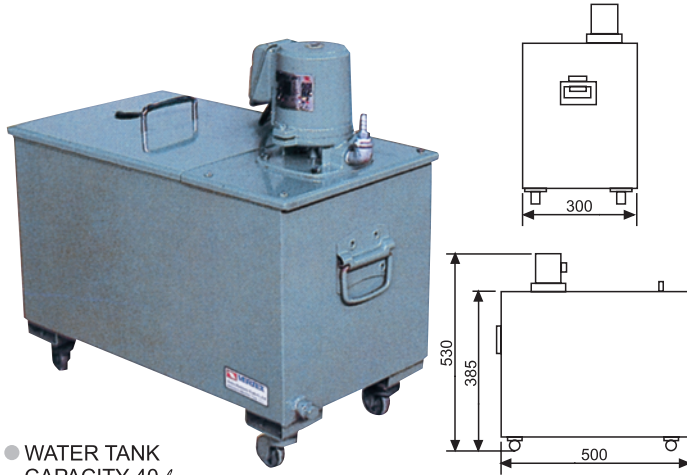

● WATER TANK CAPACITY 40 ℓ

Unit: mm

ORDER NO.	LxWxH	Motor	G.W.	CODE NO.
VC-601	500x300x530	1/8 HP	23kgs	2020-030

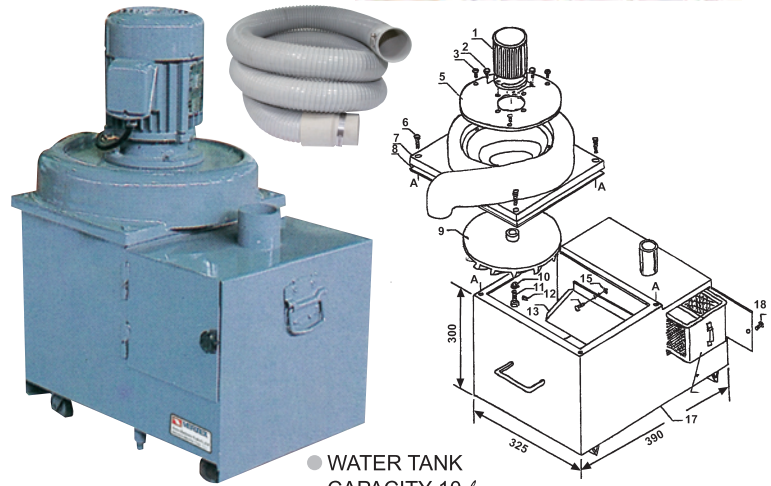

● WATER TANK CAPACITY 10 ℓ

Unit: mm

ORDER NO.	LxWxH	Motor	G.W.	CODE NO.
VC-602	560x370x720	1/2 HP	47kgs	2020-026



Dust-Suction And Coolant Tank

TWO IN ONE



PLEASE NOTIFY VOLTA & PHASE, WHEN YOU ORDERING.

Combination coolant and dust collector(10-12 J)

1. Dust suction motor 1/2 HP
2. Coolant pump 1/8 HP
3. Filter access door
4. Filter
5. Coolant return pipe
6. Dust inlet pipe ø60mm
7. Pump outlet

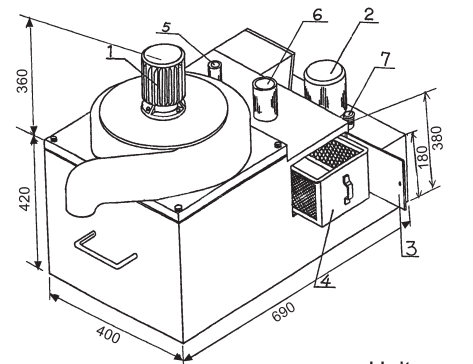

● WATER TANK CAPACITY 45 ℓ

Unit: mm

ORDER NO.	LxWxH	Motor	G.W.	CODE NO.
VC-603	690x400x780	1/2 HPx1, 1/8 HPx1	80kgs	2020-027



Dust-Suction & Coolant Tank W/Magnetic Separator

THREE IN ONE

PLEASE NOTIFY VOLTA & PHASE, WHEN YOU ORDERING.

- Suction pipe connector ø60mm
- Water tank capacity =780x700x200mm (100ℓ)

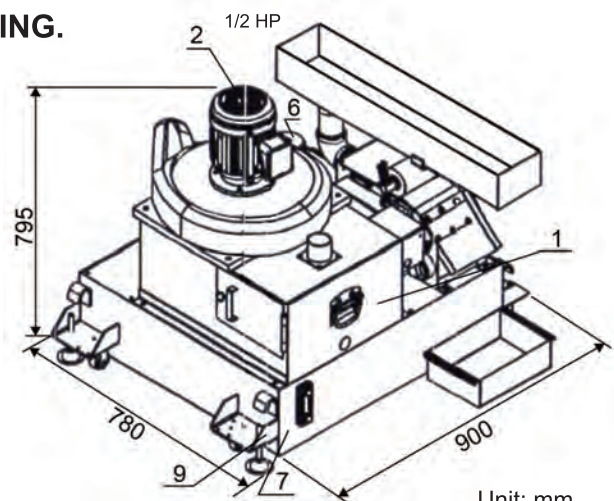
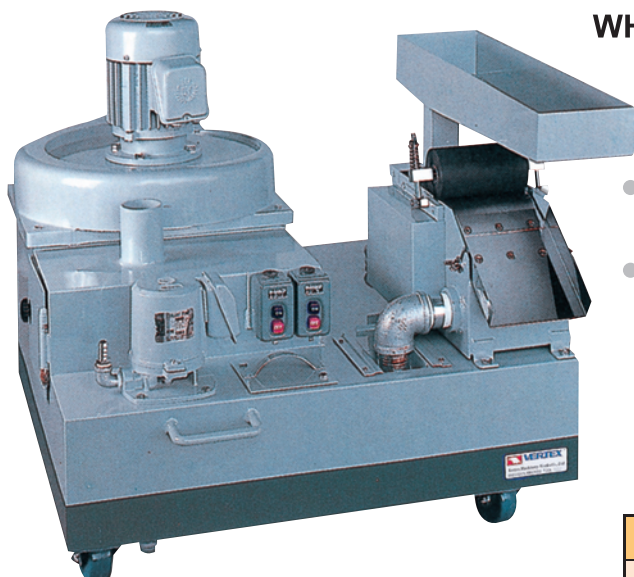

Unit: mm

ORDER NO.	LxWxH	Motor	G.W.	CODE NO.
VC-606	900x780x795	1/2 HPx1, 1/8 HPx1	110kgs	2020-028



Oil Skimmer With Belt Type



OIL SKIMMER FOR MACHINE TOOL.
FOR CLEAR FLOATING OIL ON CUTTING LIQUID.

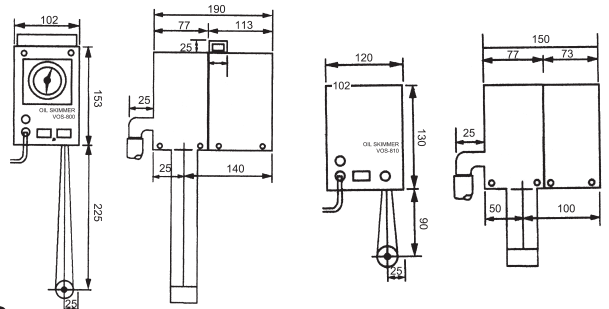

ORDER NO. VOS-800

ORDER NO. VOS-810

FEATURES

- Oily leather belt cycle for collecting oil and efficiently and completely getting rid of dirty oil.
- Much less cost of running., without any material expended.
- Small volume., light weight., easy to install and to operate.
- Special leather belt with feature of excellent durability, heat-resistance, and chemical-resistance.
- VOS-800 attached a 24 hours procedure timer to run repeatedly in accordance with time proportion which it is set, and also provides the best efficiency of sucking floating oil.

Unit: mm

ORDER NO.	POWER SOURCE	CAPACITY	DIMENSION			WEIGHT (kgs)	BELT DIMENSION		DIMENSION OF HOSE	CODE NO.
			L	B	H		B	L		
VOS-800	AC 110/220V	4L/h	190 mm	102 mm	153 mm	3.4	39x800 mm		ø22x600 mm	2020-100
VOS-810			150 mm	102 mm	138 mm	3	39x550 mm			2020-101



Oil Skimmer With Belt Type

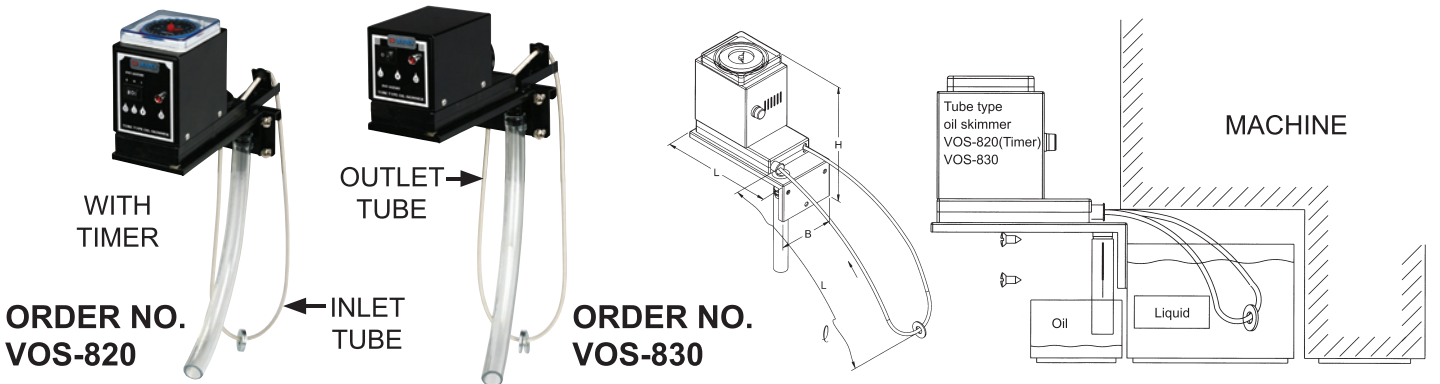

ORDER NO. VOS-820

ORDER NO. VOS-830

IF THE MACHINE DON'T HAVE SPACE FOR THE OIL SKIMMER. PLEASE CHOICE THIS TYPE.

Unit: mm

ORDER NO.	CAPACITY	DIMENSION			INLET TUBE SIZE	QUTLET TUBE SIZE		POWER SOVRCE	WEIGHT (kg)	CODE NO.
		L	B	H						
VOS-820	1L/hr	155 mm	78 mm	178 mm	1 2:300 mm	ø22	150 mm	AC 110/220V	1.9	2020-102
VOS-830		155 mm	78 mm	140 mm	1 3:200 mm				2	2020-103



Oil Skimmer With Rotary Plate Type

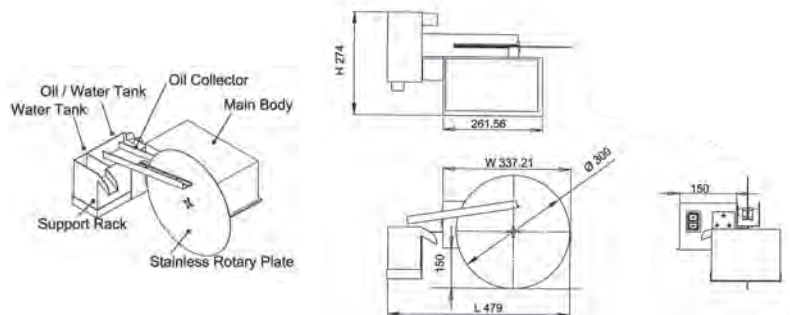

t: mm

ORDER NO.	CAPACITY	POWER SOURCE	DIMENSION			WEIGHT (kgs)	CODE NO.
			L	W	H		
VOS-850	1L/hr	AC 220V	479	337.21	274	8.6	2020-104



Precision Gauge Blocks



Gauge blocks are fundamental standards for linear measurement. For adjusting, checking, or inspecting measuring instruments and tools, and precision workpieces. Gauge blocks are used either individually or in combination of several blocks which are wrung together.

Steel gauge blocks are made of quality alloy steel, and carbide, the ceramics are also available.

The hardness number of the measuring surfaces is no less than HRC64°.

The blocks have fine wear resistance, they are heat treated in special ways so as to stabilize their lengths.

● NOT FOR LABORATORY.

JIS/ISO/DIN	ACCURACY STANDARD	
SIZE OVER UP TO	ACCURACY AT 20°C (µm)	
	GRADE 00	GRADE 0
10mm	±0.06	±0.12
10 - 25mm	+0.07	±0.14
25 - 50mm	±0.10	±0.20
50 - 75mm	±0.12	±0.25
75 - 100mm	±0.14	±0.30
100 - 150mm	-	±0.40

SIZE OVER UP TO	ACCURACY AT 20°C (µm)	
	GRADE 1	GRADE 2
10mm	±0.20	±0.45
10 - 25mm	±0.30	±0.60
25 - 50mm	±0.40	±0.80
50 - 75mm	±0.50	±1.00
75 - 100mm	±0.60	±1.20
100 - 150mm	±0.80	±1.60

STEEL METRIC GAUGE BLOCKS

ORDER NO.	Total blocks	Nominal dimension	Steps	No. of blocks	Grade	Weight (kg)	CODE NO.
VGB-112-0	112	1.0005	-	1	0	3.7	2006-070
VGB-112-1		1.001-1.009	0.001	9	1	3.7	2006-170
VGB-112-2		1.01-1.49	0.01	49	1	3.7	2006-170
		0.5-24.5	0.05	49	2	3.7	2006-270
		25-100	25	4	2	3.7	2006-270
VGB-103-0	103	1.005	-	1	0	3.6	2006-072
VGB-103-1		1.01-1.49	0.01	49	1	3.6	2006-172
VGB-103-2		0.5-24.5	0.5	49	1	3.6	2006-172
		25-100	25	4	2	3.6	2006-272
VGB-87-0	87	1.001-1.009	0.001	9	0	3	2006-073
VGB-87-1		1.01-1.49	0.01	49	1	3	2006-173
VGB-87-2		0.5-9.5	0.5	19	1	3	2006-173
		10-100	10	10	2	3	2006-273
VGB-47-0	47	1.005	-	1	0	2.4	2006-074
VGB-47-1		1.01-1.09	0.01	9	1	2.4	2006-174
VGB-47-2		1.1-1.9	0.1	9	1	2.4	2006-174
		1-24	1	24	2	2.4	2006-274
		25-100	25	4	2	2.4	2006-274
VGB-38-0	38	1.005	-	1	0	2.5	2006-075
VGB-38-1		1.01-1.09	0.01	9	1	2.5	2006-175
VGB-38-2		1.1-1.9	0.1	9	1	2.5	2006-175
		1-9	1	9	2	2.5	2006-275
		10-100	10	10	2	2.5	2006-275

CARBIDE METRIC GAUGE BLOCKS

ORDER NO.	Total blocks	Nominal dimension	Steps	No. of blocks	Grade	Weight (kgs)	CODE NO.
VGB-112T-0	112	1.0005	-	1	0	5.8	2006-080
VGB-112T-1		1.001-1.009	0.001	9	1	5.8	2006-180
		1.01-1.49	0.01	49	1	5.8	2006-180
		0.5-24.5	0.05	49	2	5.8	2006-280
		25-100	25	4	2	5.8	2006-280
VGB-103T-0	103	1.005	-	1	0	5.6	2006-081
VGB-103T-1		1.01-1.49	0.01	49	1	5.7	2006-181
VGB-103T-2		0.5-24.5	0.5	49	1	5.7	2006-181
		25-100	25	4	2	5.7	2006-281
VGB-87T-0	87	1.001-1.009	0.001	9	0	4.8	2006-082
VGB-87T-1		1.01-1.49	0.01	49	1	4.9	2006-182
VGB-87T-2		0.5-9.5	0.5	19	1	4.9	2006-182
		10-100	10	10	2	4.8	2006-282
VGB-47T-0	47	1.005	-	1	0	4.8	2006-083
VGB-47T-1		1.01-1.09	0.01	9	1	4.8	2006-183
VGB-47T-2		1.1-1.9	0.1	9	1	4.8	2006-183
		1-24	1	24	2	4.8	2006-283
		25-100	25	4	2	4.8	2006-283



Ceramic Gauge Blocks



CHOICE DIFFERENT SIZE GAUGE BLOCK FOR TOTAL THE HEIGHT

Gauge blocks are fundamental standards for linear measurement. For adjusting, checking, or inspecting measuring instruments and tools, and precision workpieces.

Gauge blocks are used either individually or in combination of several blocks which are wrung together.

● NOT FOR LABORATORY.

JIS/ISO/DIN ACCURACY STANDARD

SIZE OVER UP TO	ACCURACY AT 20°C (µm)	
	GRADE 00	GRADE 0
10mm	±0.06	±0.12
10 - 25mm	+0.07	±0.14
25 - 50mm	±0.10	±0.20
50 - 75mm	±0.12	±0.25
75 - 100mm	±0.14	±0.30
100 - 150mm	-	±0.40

SIZE OVER UP TO	ACCURACY AT 20°C (µm)	
	GRADE 1	GRADE 2
10mm	±0.20	±0.45
10 - 25mm	±0.30	±0.60
25 - 50mm	±0.40	±0.80
50 - 75mm	±0.50	±1.00
75 - 100mm	±0.60	±1.20
100 - 150mm	±0.80	±1.60

CERAMIC GAUGE BLOCKS

ORDER NO.	Total blocks	Nominal dimension	Steps	No. of blocks	Grade	Weight (kgs)	CODE NO.
VGB-112C-0	112	1.0005	-	1	0	3.7	2006-090
VGB-112C-1		1.001-1.009	0.001	9	0	3.7	2006-190
VGB-103C-0	103	1.005	-	1	0	3.6	2006-091
VGB-103C-1		1.01-1.49	0.01	49	0	3.6	2006-191
VGB-87C-0	87	1.001-1.009	0.001	9	0	3	2006-092
VGB-87C-1		1.01-1.49	0.01	49	0	3	2006-192
VGB-47C-0	47	1.005	-	1	0	2.4	2006-093
VGB-47C-1		1.01-1.09	0.01	9	0	2.4	2006-193
		1.1-1.9	0.1	9			
		1-24	1	24			
		25-100	25	4			

HOW TO CHOOSE THE BLOCK FOR SINE BAR

DISTANCE GAUGE BLOCK CAN GET DEGREE	SIN BAR CENTER	SIN BAR CENTER
2°	1.7405	3.4899
3°	2.6168	5.2336
4°	3.4878	6.9756
5°	4.3578	8.7155
6°	5.2264	10.4528
7°	6.0935	12.1869
8°	6.9587	13.9173
9°	7.8217	15.6434
10°	8.6824	17.3648
11°	9.5404	19.0809
12°	10.3956	20.7911
13°	11.2476	22.4951
14°	12.0961	24.1921
15°	12.9401	25.8819
16°	13.7819	27.5637
17°	14.6186	29.2371
18°	15.4058	30.9017
19°	16.2784	32.5586
20°	17.1010	34.2020
21°	17.9184	35.8367
22°	18.7303	37.4606
23°	19.5366	39.0713
24°	20.3368	40.6736
25°	21.1309	42.2618
26°	21.9186	43.8371
27°	22.6995	45.3990
28°	23.4736	46.9471
29°	24.2405	48.4809
30°	25.0000	50.0000
31°	25.7519	51.5038
32°	26.4960	52.9919
33°	27.2320	54.4639
34°	27.9596	55.9192
35°	28.6788	57.3576
36°	29.3893	58.7785
37°	30.0908	60.1815
38°	30.7831	61.5661
39°	31.4660	62.9320
40°	32.1394	64.2787
41°	32.8030	65.6059
42°	33.4565	66.9130
43°	34.0999	68.1998
44°	34.7329	69.4658
45°	35.3553	70.7106

CERAMIC GAUGE BLOCKS