



Mini Type Arm Type Air Tapping Unit VERTEX®

HIGH TORQUE HIGH EFFICIENCY EASY OPERATION



※Base not included

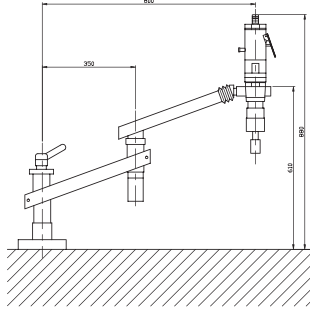

ACCESSORIES

- Air tapping spindle
- Parallel arm
- Table mounting column
- Air combination
- Choose any six safety clutch tapping adapters
- Radial jib
- Without stand plate
- Air pressure: 6~8 kgs/cm³
- VAT-08/12 series require: 5HP compressor
- VAT-16/20 series require: 10HP compressor

ORDER NO.	VAT-708	VAT-712	VAT-716	VAT-720	VAT-722	VAT-724
For Tap	M3~M8	M5~M12	M8~M16	M10~M20	M12~M22	M14~M24
	TC-312	TC-312	TC-820	TC-820	TC-820	TC-820
Speed (rpm)	630/700	350/400	250	200	200	100
Weight (kgs)	13.2	13.1	17.3	20.6	20.6	22.1
Work Range	Rmax 700mm					
CODE NO.	3404-410	3404-411	3404-412	3404-413	3404-413A	3404-413B

AIR TAPPING UNIT



Small Arm Type Air Tapping Unit

HIGH TORQUE HIGH EFFICIENCY EASY OPERATION



※Base not included

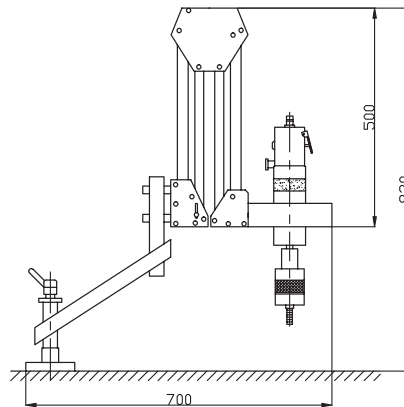

ACCESSORIES

- Air tapping spindle
- Parallel arm
- Table mounting column
- Air combination
- Choose any six safety clutch tapping adapters
- Radial jib, increases arm reach by 500mm
- Without stand plate
- Air pressure: 6~8 kgs/cm³
- VAT-08/12 series require: 5HP compressor
- VAT-16/20 series require: 10HP compressor

ORDER NO.	VAT-1408	VAT-1412	VAT-1416	VAT-1420	VAT-1422	VAT-1424
For Tap	M3~M8	M5~M12	M8~M16	M10~M20	M12~M22	M14~M24
	TC-312	TC-312	TC-820	TC-820	TC-820	TC820
Speed (rpm)	700	400	250	200	200	100
Weight (kgs)	18.2	18.2	24.6	25.6	25.6	27.1
Work Range	Rmax 1400mm					
	Rmin 200mm					
CODE NO.	3404-415	3404-416	3404-417	3404-418	3404-418A	3404-418B

※VAT-1424 can be replaced by VAT-1624

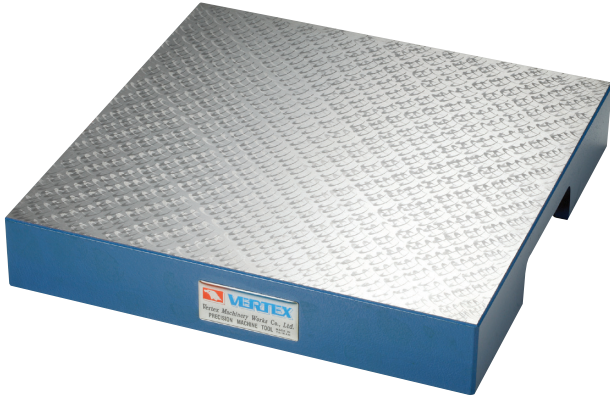

- These surface plates are designed for a diversity of applications where a smooth surface is needed.
- Rigidity and lasting accuracy are ensured by adequate top and side thickness and ribbed construction.
- The surfaces are free from pinholes. Precisely finished by planing and hand scraping, suitable for various kinds of highest precision work, inspection and countless other uses.

Surface Plates

Unit:mm

ORDER NO.	SIZE	SURFACE ACCURACY	APPROX. WEIGHT	CODE NO.
	mm		kgs	
VS-01	200x200x50	0.005/100	7.1	2021-001
VS-02	250x250x50		11.1	2021-002
VS-03	250x300x50		10.9	2021-003
VS-04	300x300x50		12.6	2021-004
VS-05	300x400x60	0.006/100	20.1	2021-005
VS-06	300x450x65		24	2021-006
VS-07	450x450x80		50.5	2021-007
VS-08	500x500x75		56	2021-008
VS-09	450x600x100		64.5	2021-009
VS-10	600x600x100	0.007/100	78	2021-010
VS-11	600x900x110		117	2021-011
VS-12	900x900x130		220	2021-012
VS-13	900x1200x155		305	2021-013

NEW

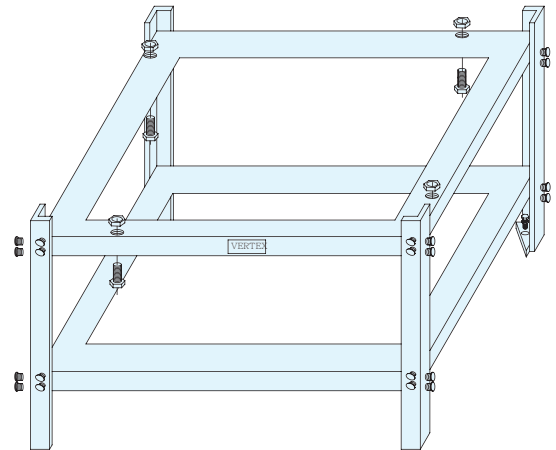

Separated Modular Design DIY Type.
Low Profile Packing
With Adjustment Screw For Leveling

Cast Iron Surface Plates Stand

ORDER NO.	STAND SIZE	KGS	CODE NO.
	mm		
VSD-09N	450x600x700		2021-009N
VSD-10N	600x600x700		2021-010N
VSD-11N	600x900x600		2021-011N
VSD-12N	900x900x600		2021-012N
VSD-13N	900x1200x600		2021-013N