

3 Jaw Standard Accuracy Scroll Chucks

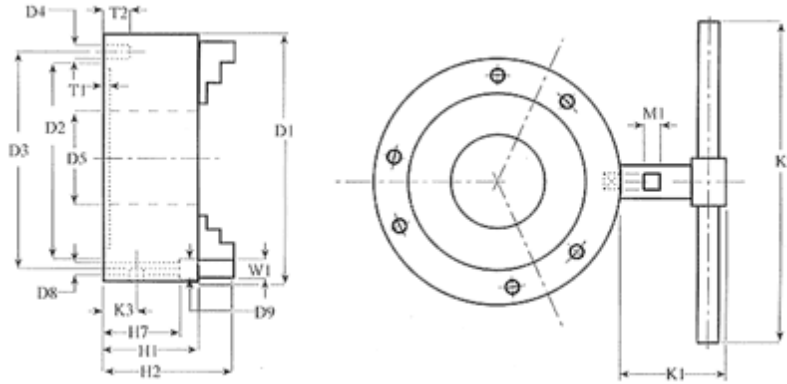

Chuck Size mm	Max Input Torque Nm	Static Grip/Jaw kN	Max RPM	Weight kg	D1	D2 H7	D3	D4	D5	D8	D9	H1	H2	H7	K1	K2	K3	M1	T1	T2	W1	Order Codes Standard Jaws	
																						Standard Accuracy	Super Precision
80	28	5.8	4000	1.7	82.5	63.5	71.3	3xM5	19	3x5.5	10	45	58	37.4	80	140	16	6	3	12	10	9580-00805	9210-00805
100	38	7.1	3800	2.9	102.4	76.2	89	3xM6	25.4	3x6.6	11	51.3	68.3	41.6	83	175	19.5	6	3	12	14	9580-01005	9210-01005
125	52	8.0	3700	4.7	125	95	108	3xM8	35	3x9	14	57	76	47	83	175	20	8	4	15	16	9580-01305	9210-01305
160	75	11.2	3500	8.6	160	125	140	3xM10	45.9	3x11	17	63.9	86.9	52	101	200	23	9	4	20	18	9580-01705	9210-01705
200	115	15.6	3200	15.6	200	160	176	3xM10	54.8	3x11	17	74.2	103.2	60	132	285	26	11	4	22	22	9580-02005	9210-02005
250	156	18.7	2800	27	250	200	224	3xM12	75.9	3x13	20	82.2	115.2	64.2	145	315	31	12	5	25	25	9580-02505	9210-02505
315	203	22.3	2300	45	310	260	286	3xM12	105	3x13	20	91	131	75	158	350	31.5	14	5	32	32	9580-03205	9210-03205
400	203	24.5	2000	83	400	330	362	3xM16	136	3x17	26	100.7	150.7	72	225	450	38.5	17	5	32	32	9580-04005	9210-04005
500	250		1100		500	420	458	6xM16	190	6x17		120	174					17	8			9580-05105	

Note: When ordering chucks with 2 piece jaws change the last 2 digits (05) in the order code to 15.
 All dimensions are in millimetres unless stated otherwise.
 + Assumes 25% loss of grip.

1 Piece Jaws (Inside & Outside)

Supplied as standard

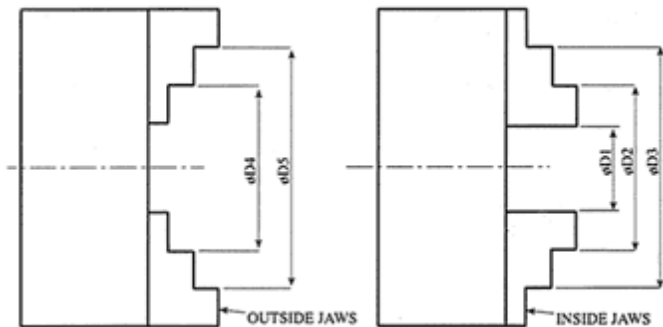

Chuck Size MM	D1	D2	D3	D4	D5
80	1-32	24-44	50-78	28-50	50-76
100	1-32	25-56	56-90	28-60	60-98
125	1.5-32	28-78	70-120	38-84	78-124
160	1.5-56	42-98	84-152	48-106	90-160
200	2-76	56-126	115-186	54-128	114-200
250	3-114	60-168	148-250	64-162	150-250
315	6-120	70-184	184-298	76-190	190-304
400	10-187	90-268	223-400	92-270	224-406

2 Piece Reversible Hard Top Jaws

Supplied as alternative

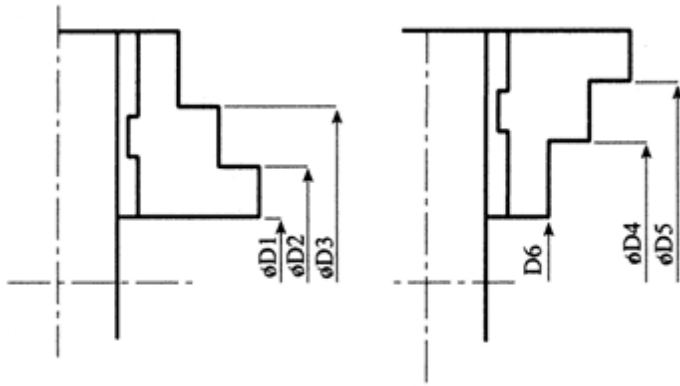

Chuck Size MM	D1	D2	D3	D4	D5	D6
100	1.5-28	24-50	60-86	39-66	75-102	5-32
125	1.5-48	32-80	72-118	48-94	90-136	5-51
160	1.5-62	42-102	98-158	48-108	108-168	10-70
200	2.5-68	50-116	106-172	64-130	122-188	16-82
250	4-106	66-164	124-226	84-186	146-248	16-120
315	6-126	70-190	146-266	98-218	178-298	18-138
400	8-168	110-270	178-338	106-266	176-336	20-180