

Traversing Lathe Guards

- Machine Type - Light to medium centre lathes
- Method of attachment - Secures to lathe saddle
- Manually adjusted to cover work area
- Construction - Cast aluminum and 4 mm polycarbonate visors
- Operation - Traverses with saddle hinges to allow access to chuck and work area

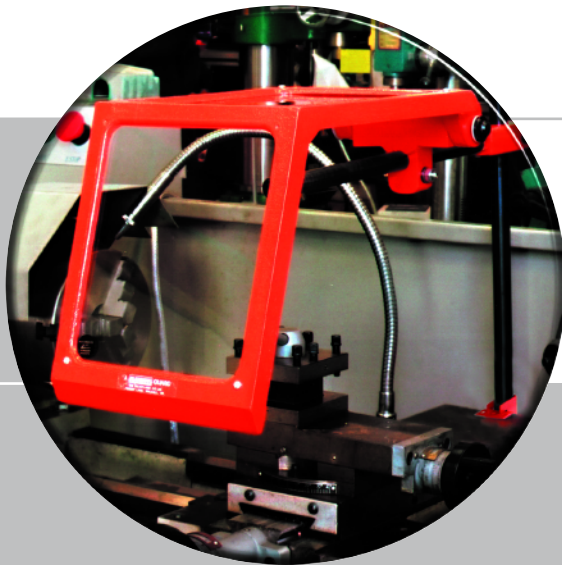

Model - SL6, SL12 & SL18

19

Technical Data:

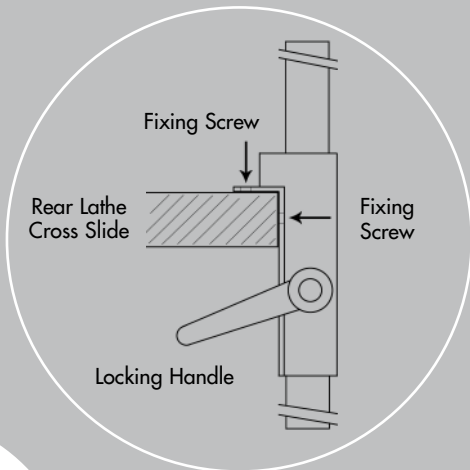

Interlocks can be fitted if required to all models.

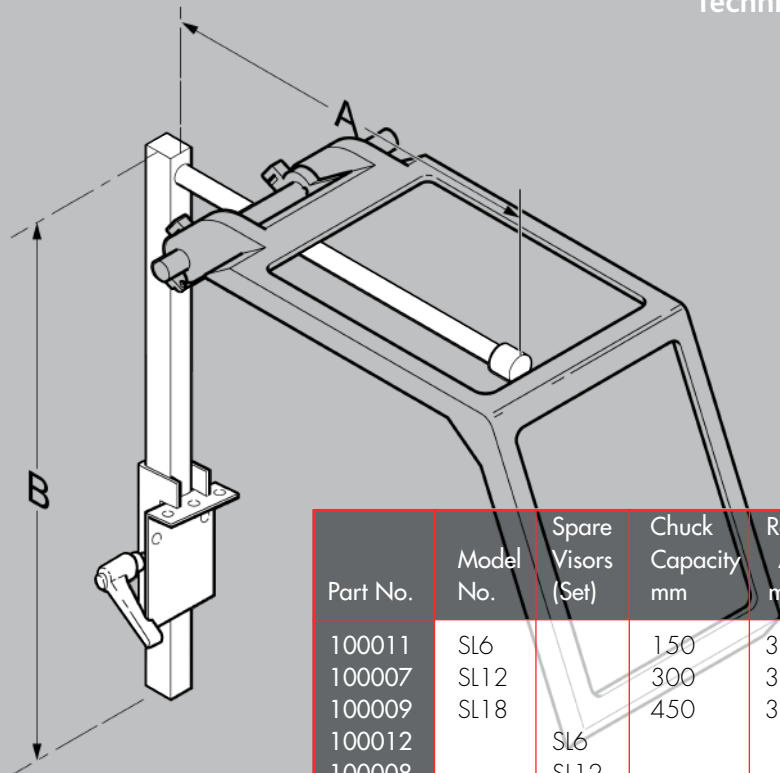

Part No.	Model No.	Spare Visors (Set)	Chuck Capacity mm	Rod Lengths	
				A mm	B mm
100011	SL6		150	335	510
100007	SL12		300	335	510
100009	SL18		450	335	510
100012		SL6			
100008		SL12			
100010		SL18			