

Features:

- Additional adjusted body support in horizontal position
- Up to 90° angle of incline from the horizontal position
- 360° swivel base with ground contact edge and graduation
- Thrust bearing in the power transmission enables easy operation.
- Removable grooved jaw inserts are hardened and ground, ensuring longer life with maintained accuracy and repeatability
- Sturdy design of fully covered cast iron lead screw

Application:

- Designed for milling, planing and drilling when two angle settings occur

Standard accessories:

- Handcrank
- Slot nuts

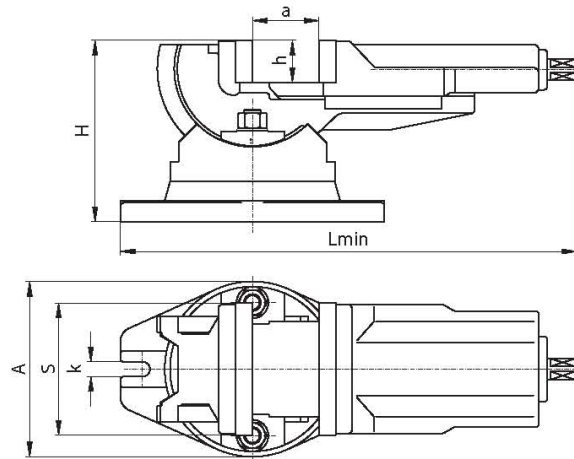

Accessories see pages 152-162



Type 6530

TWO ANGLE SWIVEL MACHINE VISE

Code No.	Type	S	A	H	L	a _{max}	h	k	Max. clamping force [daN]	kg
326530050400	6530-100	100	144	145	372	80	32	14	2.500	12,5
326530060600	6530-125	125	168	169	437	100	40	14	3.500	20,0
326530070800	6530-160	160	212	200	450	125	50	18	4.000	34,2

Features:

- Centric clamping by right-hand and left-hand threaded spindle
- 360° swivel base with ground contact edge and graduation
- Removable grooved jaw inserts are hardened and ground, ensuring longer life with maintained accuracy and repeatability
- Sturdy design of cast iron

Application:

- Designed for various types of milling and planing of forms, slots and grooves

Standard accessories:

- Handcrank
- Slot nuts

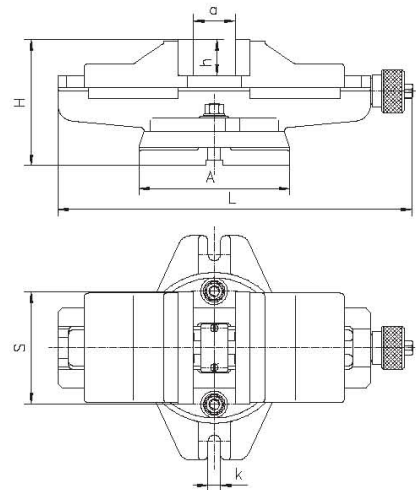

Accessories see pages 152-162

SELF-CENTERING MACHINE VISE

Type 6531



Code No.	Type	S	A	H	L	a _{max}	h	k	Max. clamping force [daN]	kg
326531060400	6531-125	125	168	136	458	100	40	14	3.500	19,2
326531070600	6531-160	160	212	169	534	125	50	14	4.000	33,5
326531080800	6531-200	200	286	185	591	160	63	18	5.500	59

- 1
- 2
- 3
- 4
- 5
- 6

- 6530
- 6531