

VERTICAL MILLING MACHINE (MANUALLY OPERATED) - MAX-A-JUST®

- Machine Type - Manually operated milling machines
- Method of attachment - Adjustable rail secured to machine table with T. Nuts (1 per side)
- Positive Manual latch
- Construction - Mild steel adjustable polycarbonate visors
- Operation - Vizors adjusted around machine cutters, hinges open to give access to tooling

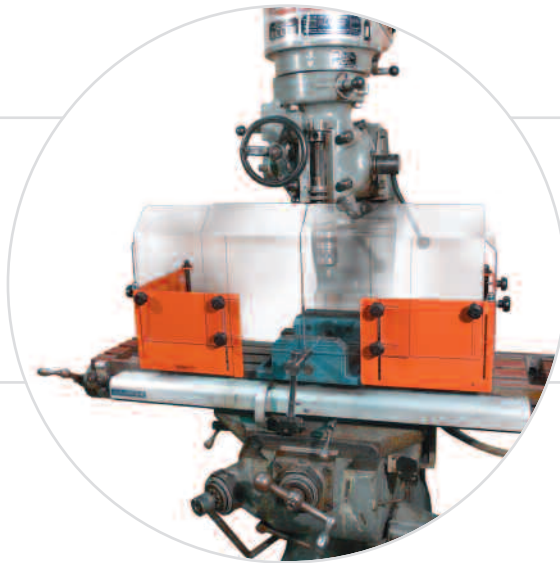
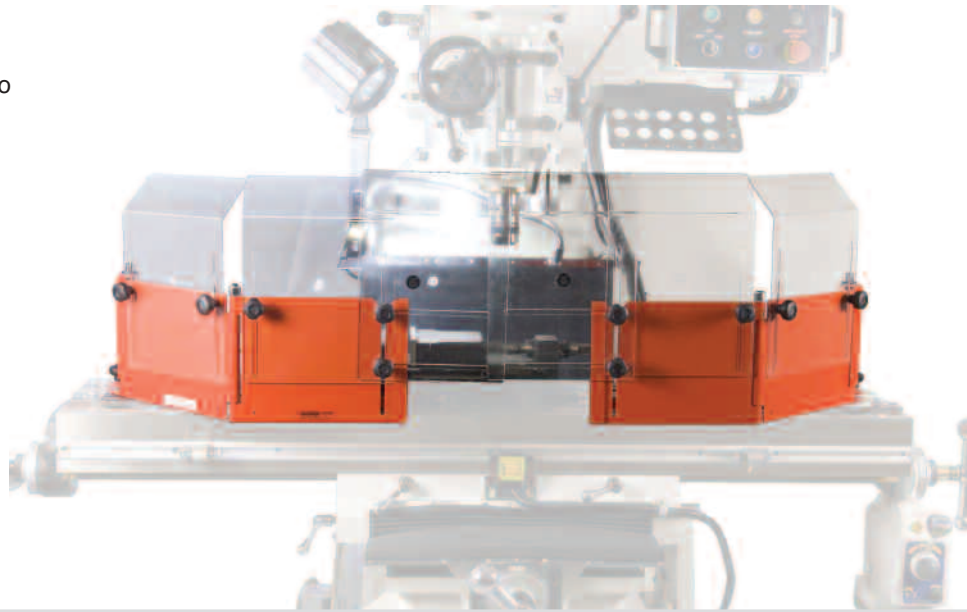

TECHNICAL DATA:

| | MAX-A-JUST Model M1 | MAX-A-JUST Model M2 |
|-------------------------|------------------------|------------------------|
| Minimum Vertical Height | 200mm | 250mm |
| Maximum Vertical Height | 350mm | 450mm |
| Minimum overall | | |
| Length enclosing | 375mm | 475mm |
| Maximum overall | | |
| Length enclosing | 525mm | 800mm |
| Minimum overall | | |
| Length extended | 700mm | 925mm |
| Maximum overall | | |
| Length extended | 875mm | 1250mm |

(Both sides
extended in line)

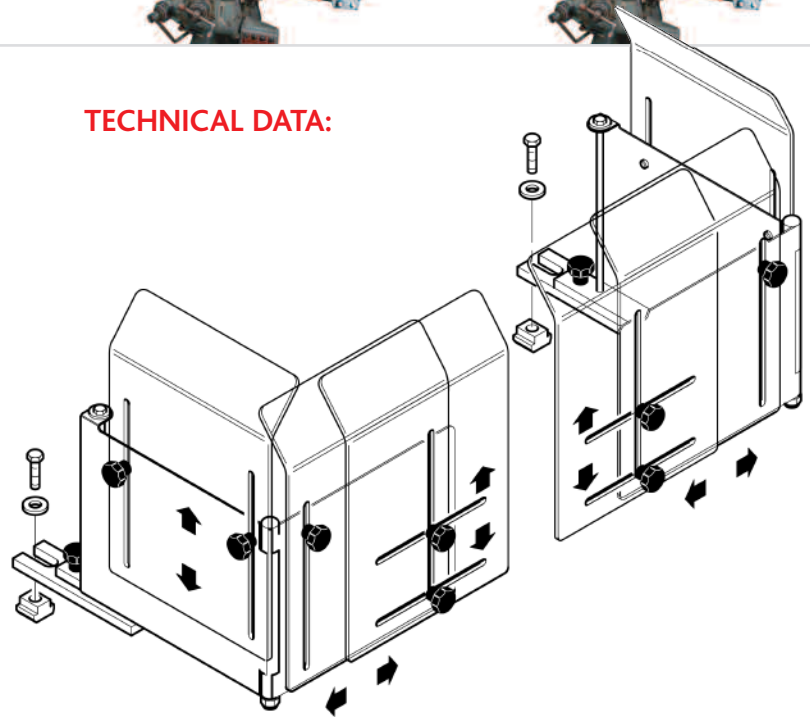

Smallest T-Nut available 12mm
Largest T-Nut available 18mm

| Part No. | Model |
|----------|-------|
| 20001 | M1 |
| 20002 | M2 |

Spare Visors (Set of 6)

| Part No. | Model |
|----------|-------|
| 20003 | M1 |
| 20004 | M2 |

**important:
when ordering
please specify
'tee slot' size**

