

Static Lathe Guards

- Machine Type - Light to medium centre lathes
- Method of attachment - Secures to face or top of lathe headstock
- Manually adjusted to cover work area. Interlock available
- Construction - Cast aluminum and 4 mm polycarbonate visors
- Operation - Hinges to allow access to chuck and work area



L6



L12 & L18



Model - L6, L12 & L18

18

Electrical Interlock

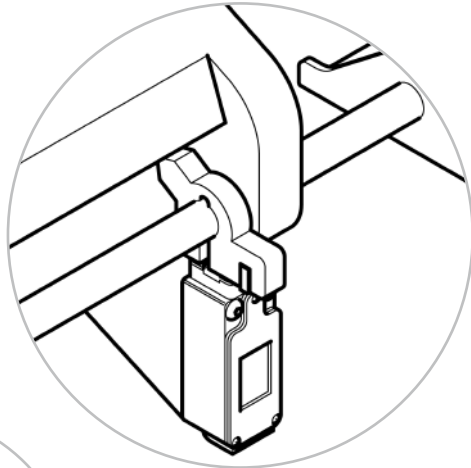

Interlocks can be fitted if required to all models.

Technical Data:

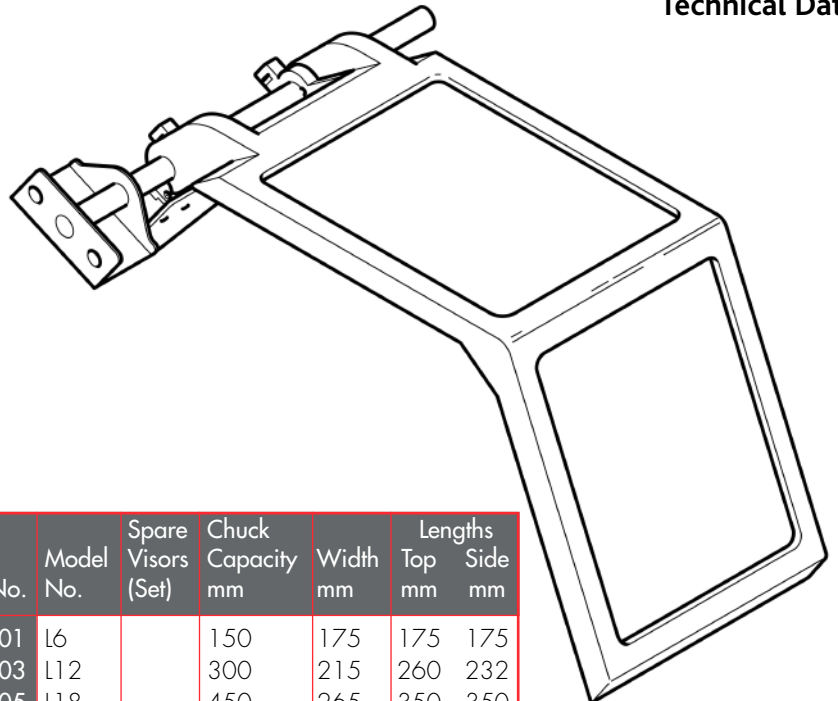

Part No.	Model No.	Spare Visors (Set)	Chuck Capacity mm	Width mm	Lengths	
					Top mm	Side mm
100001	L6		150	175	175	175
100003	L12		300	215	260	232
100005	L18		450	265	350	350
100002		L6				
100004		L12				
100006		L18				