

Our Guards

Grinding Machine

Grinding Machine Guards

Complete Guards

Part No.	Model	Wheel Size	Frame Size
130003	SGB	200 mm	159 x 133 mm
130005	ST	275 mm	215 x 160 mm
130007	ST/1	300 mm	324 x 305 mm



Model: SGB



Model: ST



Model: ST 1

Spare Visors

- Machine Type - Wheel size dependant
- Method of attachment - Secures to existing wheel guard
- Manually adjusted by pinch bolt
- Operation - Eye protection

Construction

ST/SGB Moulded nylon frame 5mm polycarbonate visor
 ST/1 Cast aluminium frame 5 mm polycarbonate visor

Part No.	Model	Visor Size mm
130004	SGB	150 x 125 mm
130006	ST	203 x 153 mm
130008	ST/1	295 x 295 mm

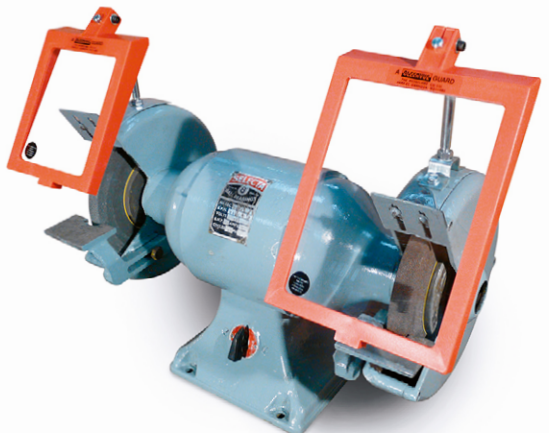

Our Guards

Grinding Machine

Pedestal Grinder Guard

Complete Guards

Part No.	Weight	Visor A	Visor B
PMA 11/112	3.2kg	160 mm	145 mm
PMA 11/216	3.4kg	200 mm	185 mm



Model: PMA



Model: PMA

Construction

- 1 Anchorage Stirrups in Pressed Steel
- 2 Adjustable Support Arms in Steel Hexagon
- 3 Shield Group Rotation Hinge, integrated with Safety Microswitch
- 4 Articulated Clamp for the Horizontal and Vertical adjustment
- 5 Shield Support border in Aluminium Profile
- 6 Shield in Plastic Shockproof Material

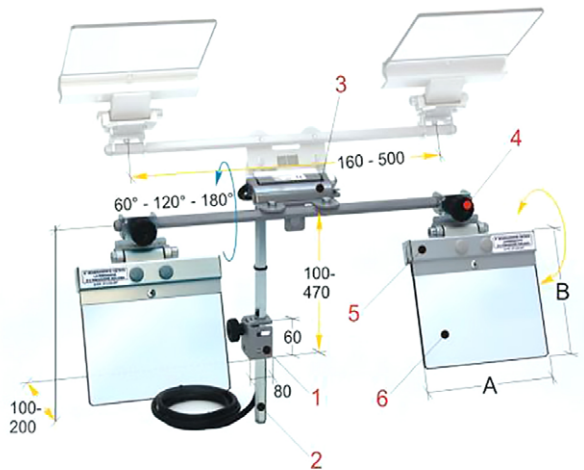

Pedestal Grinder Guard

- Protects the Operators face from the Projection of Sparks and Grinding Dust
- Multi-adjustable Hexagonal Arm Structure allows for an easy fit on a large number of Grinding Machines
- This impressive Arm Structure enables Excellent Variability
- This product can be used on Machines with the Grindstone in the "Overhang" Position
- The Hinge that supports the Protective Shield is integrated with a Safety Microswitch conforming to EN 1088
- High quality build ensuring maximum protection
- Operator friendly and does not restrict flow of production
- All "Next Generation" Machine Guards are in conformance with P.U.W.E.R (1998) and come with a Certificate of Conformity

Our Guards

Grinding Machine

Cylindrical Grinder Guard



Model: SGG

Complete Guards

Part No.	Model
13010	SGG
13011	SGG with Interlock

Construction:

- Full length sliding windows giving immediate access for Component loading and setting
- Mounted on our unique Self-Cleaning Roller System
- Positive Latch
- Available with Interlock Switch

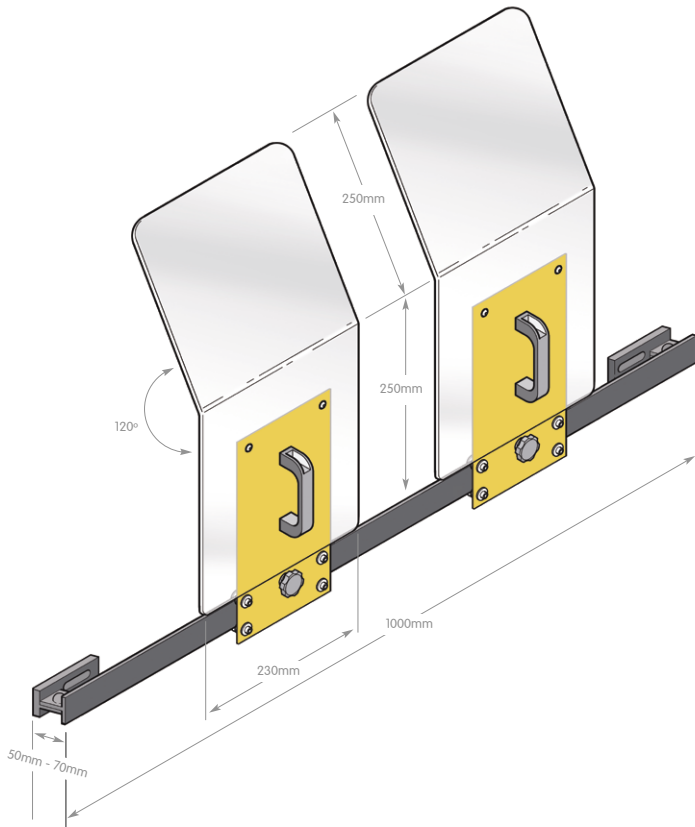

Our Guards

Grinding Machine

Universal Grinder Guard

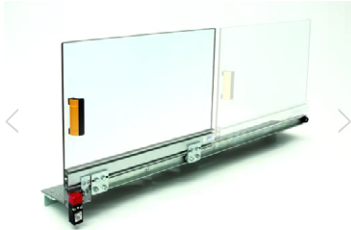

Model: PRE 01

Complete Guards

Part No.	Weight	Visor A	Visor B
PRE 01/650	16.5kg	1200 mm	500 mm
PRE 01/860	20.5kg	1600 mm	600 mm

Construction

- 1 Anchorage Stirrups in Pressed Steel
- 2 Inclined support sheet metal in sheet steel
- 3 Safety microswitch with separated actuator with n.2 NC contacts
- 4 Steel sliding guide with tempered bearings
- 5 Shield support structure in aluminium profile
- 6 Shield in shockproof and oil-resistant, thick, plastic material



93/1844

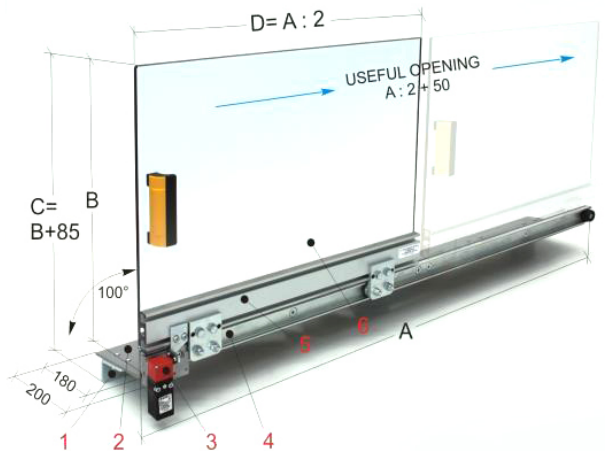

PRE 01 - Universal Grinder Guard

- The PRE 01 protects the operator from direct contact with the Rotating Grindstone, Components and protruding lubricant-coolant
- Attached to the Machine by point 1
- Equipped with a Sliding Door, moving smoothly on Steel Guides positioned on the outer edge of the guard
- Shockproof Polycarbonate Screen Door, ensuring excellent visibility and resistance
- Guard Frame is Steel, with an inbuilt drip tray which collects coolant
- Operator friendly, does not restrict flow of production and ensures maximum safety is achieved
- Complete with safety micro-switch conforming to EN 1088
- All Machine Guards are in conformance with P.U.W.E.R (1998) and come with a Certificate of Conformity

Our Guards

Grinding Machine

Surface Grinder Guard



Model: PRE 10

Complete Guards

Part No.	Weight	Visor A	Visor B
PRE 10/550	14.7kg	1000 mm	510 mm
PRE 10/655	17.5kg	1200 mm	560 mm
PRE 10/860	21.6kg	1600 mm	660 mm

Construction

- 1 Angular Anchorage Stirrups in Pressed Steel
- 2 Multi-adjustable support structure, with two attachment systems
- 3 Safety Microswitch with separated actuator n.2 NC contacts
- 4 Perimeter structure - in Aluminium Profile
- 5 Sliding Ball Guides, with an excursion equal to their length
- 6 Shields in shockproof and oil-resistant thick plastic material
- 7 Inner structure for lubricant liquid collection



93/1844

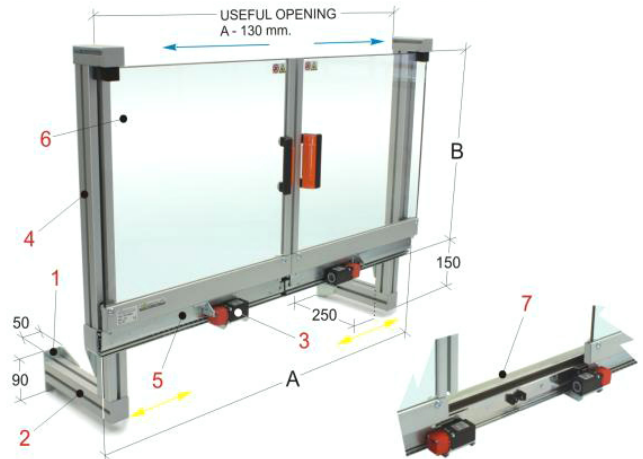

PRE 10 - Surface Grinder Guard

- The PRE 10 protects the operator from direct contact with the rotating grindstone, components and protruding lubricant-coolant
- Attaches to the base of the machine (point 1 on diagram) but two horizontal multi-adjustable supports allow the guard to be affixed from the bottom, side or front
- Shockproof Polycarbonate Screen Door, ensuring excellent visibility and resistance
- Guard Frame is Steel, with an inbuilt drip tray which collects coolant
- Operator friendly, does not restrict flow of production and ensures maximum safety is achieved
- Complete with safety micro-switch conforming to EN 1088
- All Machine Guards are in conformance with P.U.W.E.R (1998) and come with a Certificate of Conformity

Our Guards

Drilling Machine

Drilling Machine Guards

Silvaflame-Cleervue manufactures a comprehensive range of drilling machine guards to suit virtually all types and sizes of bench and pedestal drilling machines such as Startrite, Herbert, Pollard, FOBCO. These are available with or without electrical interlock systems. Bespoke drill guards are also available.



DRILLING MACHINE

1. Small Bench or Pedestal Drilling Machine Telescopic Guard
2. Medium Bench & Pedestal Drilling Machine Guards
3. Light/Heavy Radial Drilling Machine Side Opening Guard
4. PTR 02 Radial Drill Guard
5. PTR 20 Radial Drill Guard
6. PTR 04 Small-Medium Drill Guard

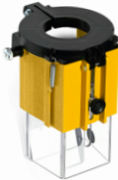

DRILLING MACHINE FIXED ADJUSTABLE

7. Light Bench or Pedestal Drilling Machine Guard - by machine make
8. Medium Bench or Pedestal Drilling Machine Interlock Guard
9. Heavy Pedestal Drilling Machine Interlock Guard Multi-spindle
10. Universal Drill Guard - SV Type
11. Universal Drill Guard - TV Type

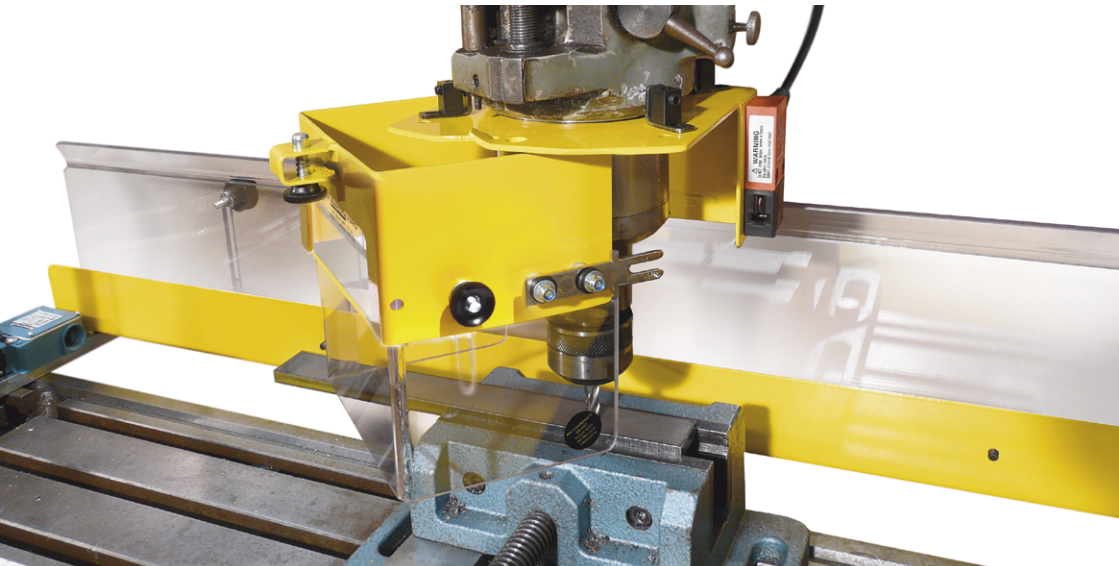

Our Guards

Drilling Machine

Small Bench or Pedestal Drilling Machine Telescopic Guard

Product Details

- Machine Type - Light/Bench or Pedestal
- Method of attachment - secures to drilling machine spindle collar
- Positive manual latch
- Flip up with spring retention
- Construction - moulded polycarbonate
- Operation - Telescopes on contact with work piece, length adjustable vizor which encloses the work area



Model: BT/2



Model: BT/4

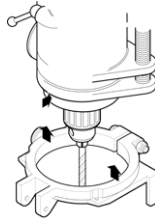

GUARD TOP No 2

Clip type bored out to suit collar size 40mm to 70mm Max.

Depth stop bracket may require raising to expose the clamping area.

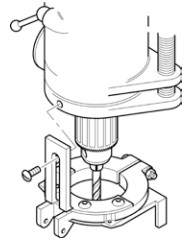

GUARD TOP No 4

This top has a single steel upright tongue which is attached to the machine by drilling and tapping a 6mm holes and bolting the guard direct to the depth stop casting.

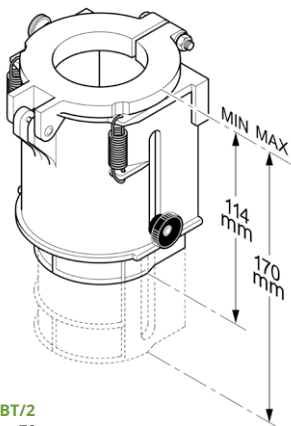

Model BT/2

Max bore 70mm
Max chuck dia 55mm

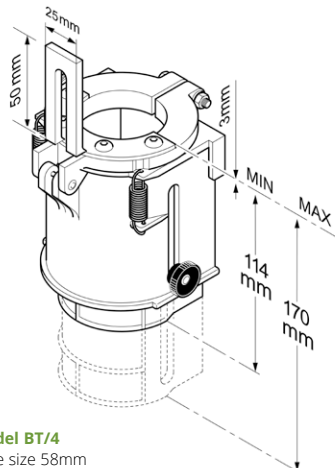

Model BT/4

Bore size 58mm

Technical Data

Top Fixing

Pedestal & Bench Drilling Machine Guards - MT, MTS & HTS selection by top fixing

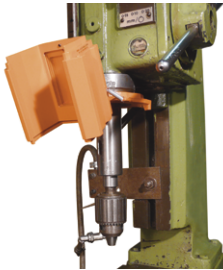

Measure Maximum and Minimum Spindle exposure.
Chose a model to suit these dimensions = **Model**.

Select a fixing top to match either the shape of depth stop or the circular collar = **Top Type**.

Measure across the fixing area for size = **Top Size & Bore**.

Example. MT/2/90mm Dia.

Make and Model of machine is also helpful.

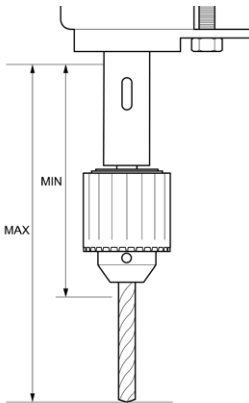

Morse Taper - Guard Type MT

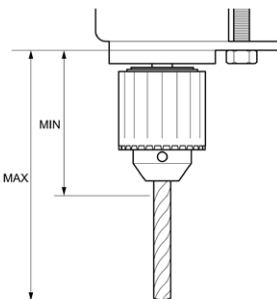

Chuck Type - Guard Type MTS

Interlock Technical

Interlock Switch Installation



Interlock switches can only be safely fitted to a machine that is equipped with a "NO VOLTAGE CONTACTOR SYSTEM" and a control circuit Voltage of 110v or less.

To check if the machine has a "NO VOLTAGE CONTACTOR SYSTEM"

Please test using the following procedure:

- Switch on the power and start the machine.
- Switch the machine off using the machine isolator NOT the stop start buttons the machine will come to a stop.
- Turn the machine isolator back on, if the machine starts straight up then the machine does not have a "NO VOLTAGE CONTACTOR SYSTEM".
- In this case a "NO VOLTAGE CONTACTOR SYSTEM" must be installed before an interlocked guard can be safely fitted.

Seek help from a qualified electrician if in any doubt.

Our Guards

Drilling Machine

Medium Bench & Pedestal Drilling Machine Guards



Model: MTS/2

Product Details

- Machine Type - Medium /Bench or Pedestal
- Method of attachment - Secures around depth stop collar using fixing top to suit configuration
- Positive Manual latch
- Flip up with spring retention
- Construction - Aluminium/Nylon with Polycarbonate Vizor which encloses the work area
- Operation - Telescopes on contact with work piece, length adjustable vizor
- Interlock Switching available - **See Interlock Technical P11.**



Model: MT/2

Model MTS/2 - Guard Top No 2

Max chuck dia 70mm

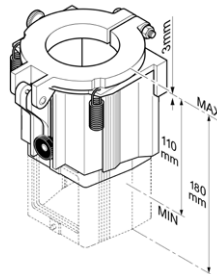

Model HTL/XL - Guard Top No 2

Max bore 50mm < 101mm

Special adaptor required for collars 101mm < 110mm

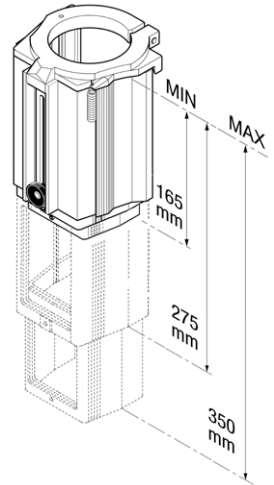

Model MT/6 - Guard Top No 6

Max chuck dia 63mm

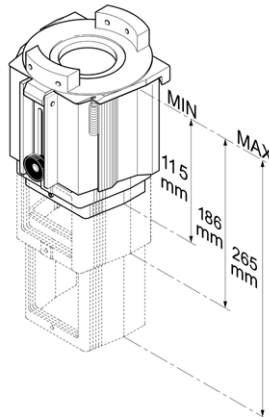

Model: HTL/XL/2

IF POSSIBLE PLEASE GIVE FULL DETAILS OF MACHINE WHEN ORDERING

CAN BE MANUFACTURED IN ANY COMBINATION OF ALUMINUM & POLYCARBONATE

Different Types of Top Fixings to suit Drilling Machines Depth Stop/Non Rotating Collars

No1 (MT / HT)

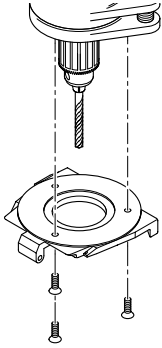

This is for fitting under the Bearing Housing and can take the place of the dust cover plate. Where quill retracts into the Head it is fitted by drilling and tapping the underneath side of the head and bolted by means of countersunk screws to the machine.

No2 (MT / HT)

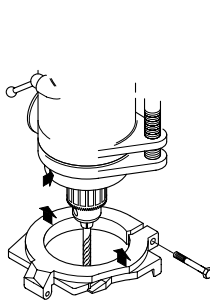

Clip type bored out to suit collar size 50mm to 101mm Max.

Depth stop bracket may require raising to expose the clamping area.

No3 (MT / HT)

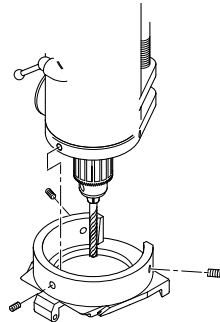

This is a special top, designed for Pollard Corona machines, model 15AX, on which the stop gauge bar rod is situated at the rear of the pear shaped stop gauge bar casting.

No3 LH (MT / HT)

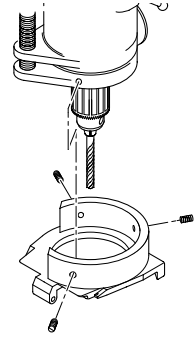

This is a special top, designed for Pollard Corona machines, models 150 and 15AY, on which the stop gauge bar rod is situated on the left of the pear shaped stop gauge bar casting.

No4 (MT / HT)

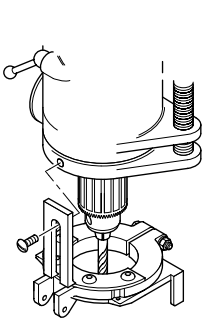

This top casting has a single steel upright tongue which is attached to the machine by drilling and tapping a 6mm holes and bolting the guard direct to the depth stop casting.

No4 (MT / HT)

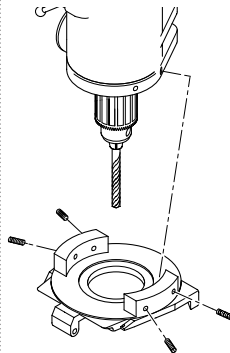

Bored to secure sides of depth-stop casting.

No6 (MT / HT)

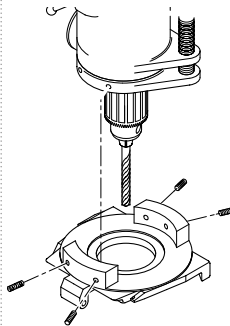

This has front and rear uprights for fitting to the non-rotating collar of machines. Should the machines have automatic feed and gear box, you will need to add C/A after the top choice has been selected. Max Spindle dia 70mm.

MT - ADJ

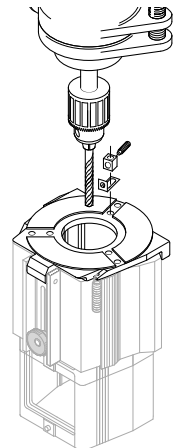

See Separate Instructions for Installation & Templates

Our Guards

Drilling Machine

Light/Heavy Radial Drilling Machine Side Opening Guard



Model: LRTS



Model: LRTL

Product Details

- Machine Type - Light/ Radial type
- Method of attachment - Secures around depth stop collar using fixing top to suit configuration
- Positive Manual latch
- Side opening
- Construction - Aluminium with Polycarbonate Vizor encloses the work area
- Operation - Telescopes on contact with work piece length adjustable vizor
- Can be extended to 350mm by adding third section. Model LRTL
- Interlock Switching available - **See Interlock Technical P11.**

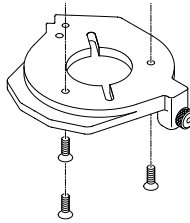

No1 (LRT)

This is for fitting under the Bearing Housing and can take the place of the dust cover plate.

Where quill retracts into the Head it is fitted by drilling and tapping the underneath side of the head and bolted by means of countersunk screws to the machine.

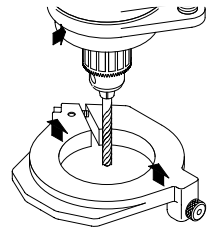

No2 (LRT)

This is an integral clamp which can be bored out to suit any non-rotating collar size from 47 to 92mm.

On some drilling machines it may be necessary to raise the stop-gauge castings to expose this collar. 93 < 109mm Dia require a special adaptor.

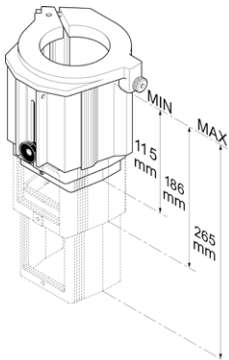

Model LRTS/2

Max Chuck dia 63mm
Max Spindle dia 70mm

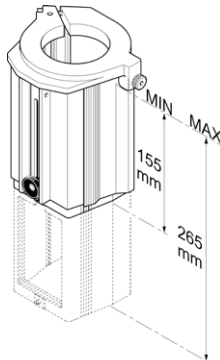

Model LRTL/2

Max Chuck dia 70mm
Max Spindle dia 70mm

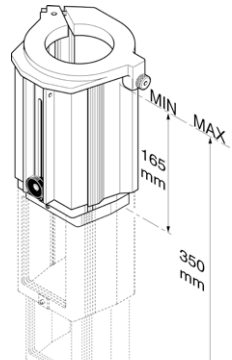

Model LRTLXL/2

Max Chuck dia 63mm
Max Spindle dia 70mm

Our Guards

Drilling Machine

PTR 02 & PTR 20 Drill & Radial Drill Guard

Complete Guards

Part No.	A - Width	B - Height	C - Depth	Weight
PTR 02/130	230 mm	130 mm	115 mm	2.5kg
PTR 02/180	230 mm	180 mm	115 mm	2.6kg
PTR 20/300	300 mm	200 mm	150 mm	3.9kg
PTR 20/350	350 mm	240 mm	175 mm	4.2kg

Construction

- 1 Anchorage Stirrup
- 2 Safety Microswitch main box - 180 degree rotation
- 3 Shield Support Vertical Arm - Steel
- 4 Arm Shield Adjustment Knob
- 5 Clamp with Shield Release Screw from the Telescopic Arm
- 6 Semi Octagonal Shield in Polycarbonate

Model: PTR 20

Model PTR 02

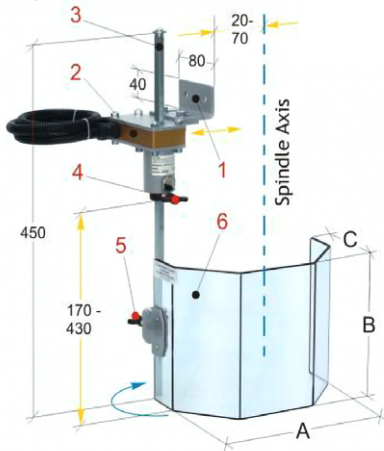

Model PTR 20

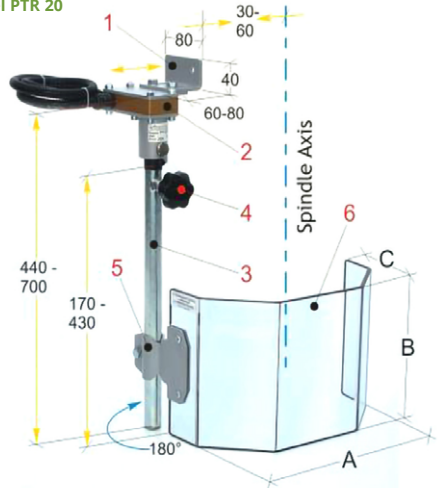

PTR 02 & PTR 20 - Drill & Radial Drill Guard

- The Guard protects operator from direct contact with rotating components, debris and coolant
- Guard attaches to the left hand side of the Machine
- The Guard is highly adaptable to your Machine; the screen is semi octagonal and is height adjustable, it can be positioned to suit on the mounting arm and the mounting arm can also be adjusted by height
- The screen is made using top quality Polycarbonate ensuring "Shock proof" resistance and excellent visibility
- Comes complete with Safety Microswitch conforming to EN 1088.
The Microswitch stops the machine from operating when the guard is in the open position
- Guards do not disrupt the operators work flow whilst maintaining maximum safety at all times
- All Machine Guards meet with P.U.W.E.R (1998) and come with a Certificate of Conformity

Our Guards

Drilling Machine

PTR 04 - Small-Medium Drill Guard

Complete Guards

Part No.	A - Width	B - Height	C - Depth	Weight
PTR 04/140	200 mm	140 mm	100 mm	1.8kg

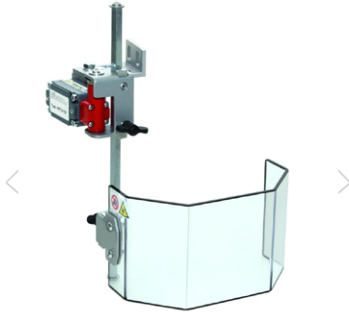

Model: PTR 04/140

Construction

- 1 Anchorage Stirrup in Pressed Steel
- 2 Self Bearing Safety Microswitch 180 degree rotation
- 3 Shield Support Vertical Arm in steel hexagon
- 4 Arm Shield Adjustment Knob
- 5 Shield Adjustment Knob
- 6 Semi Octagonal Shield in Polycarbonate

PTR 04 - Small-Medium Drill Guard

- The PTR 04 Guard protects from direct contact with rotating spindle parts and the projection of swarf and coolant
- Guard attaches to the left hand side of the machine
- The screen is semi octagonal and is made using top quality polycarbonate ensuring "Shock proof" resistance and excellent visibility
- The Guard is highly adaptable to your machine
- The semi-octagonal shield can adjust vertically in two different ways:
 1. It can be adjusted by points 4 or 5 on shield arm (see Diagram)
 OR
 2. It can be adjusted by the support clamp on the inside mounting plate or the outside mounting plate. This allows a variety of horizontal adjustments to be made.

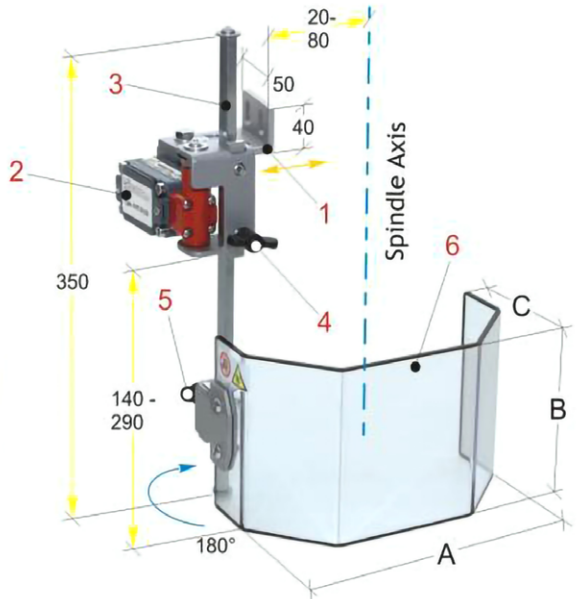

- Comes complete with Safety Microswitch conforming to EN 1088
The Microswitch stops the machine from operating when the guard is in the open position
- Guards do not disrupt the operators work flow whilst maintaining maximum safety at all times
- All Machine Guards meet with P.U.W.E.R (1998) and come with a Certificate of Conformity

Technical Data Drilling Machines

Light Bench or Pedestal Drilling Machine Guard by Machine Make



Model: BP-1

Product Details

- Machine Type - Light /Bench or Pedestal (dedicated to machine make)
- Method of attachment - Clips to back pillar
- Positive Manual latch or interlock
- Side opening
- Construction - Mild steel with 4 mm polycarbonate vizor
- Operation - Remains stationary allowing depth stop collar and chuck to pass through length adjustable vizor
- Interlock Switching available - See Interlock Technical P11.

MAKE AND MODEL NUMBER ARE HELPFUL

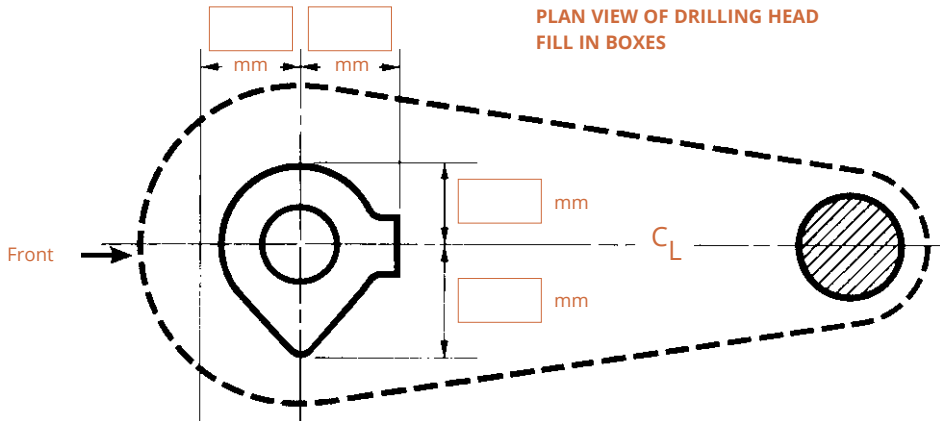

SIZE & SHAPE OF DEPTH STOP CLAMP MUST BE COMPLETED:

ONLY SUITABLE FOR CLAMPING TO BACK PILLAR OF 50mm MIN. UP TO 89mm MAX.

Make and model of machine MUST BE STATED together with sketch and dimensions.

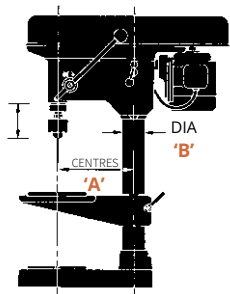

Dimension 'A'.....

Dimension 'B'.....

Our Guards

Drilling Machine

Medium Bench or Pedestal Drilling Machine Interlock Guard

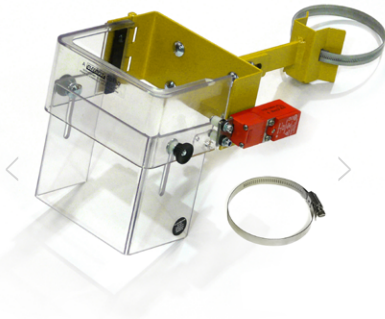

Model: BP-2

Product Details

- Machine Type - Light/ Bench or Pedestal
- Method of attachment - Clips to back pillar
- Positive Manual latch or interlocked
- Side opening
- Construction - Moulded 5mm polycarbonate body, with 4 mm polycarbonate vizor, adjustable to suit machine depth stop bracket
- Operation - Remains stationary allowing depth stop collar and chuck to pass through length adjustable vizor
- Interlock Switching available - See **Interlock Technical P11**.

Part No.	Model
80020	BP-2
80021	BP-2 Interlock

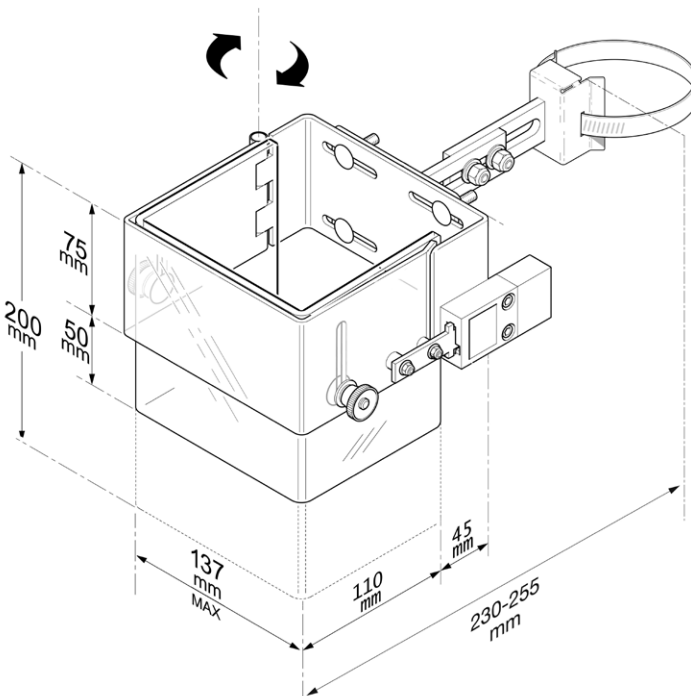

Model BP-2 Interlock

Ordering Information

- **Dimension of back pillar required**
- Order RR Bracket if with Rear Rack
- Order FR Bracket for Front Rack
- Ensure Depth Stop Clamp will pass through guard without fouling

Our Guards

Drilling Machine

Heavy Pedestal Drilling Machine Interlock Guard Multi-spindle



Product Details

- Machine Type - Heavy/Pedestal
- Method of attachment - attaches to back column
- Positive manual latch or interlocked
- Side opening
- Construction - mild steel with polycarbonate vizor adjustable to suit machine depth stop bracket
- Operation - remains stationary allowing depth stop collar and chuck to pass through length adjustable vizor
- Special made to measure size BP-3 available
- Type of pillar - Herbert or Pollard
- Dimension of slot or dovetail
- Manual or interlocked
- Interlock Switching available - See Interlock Technical P11.

Model: BP-3

Part No.	Model
10003	Herbert & Archdale
10004	Pollard Corona

Model BP-3

Ordering Information

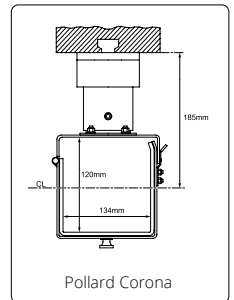
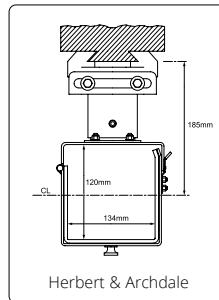
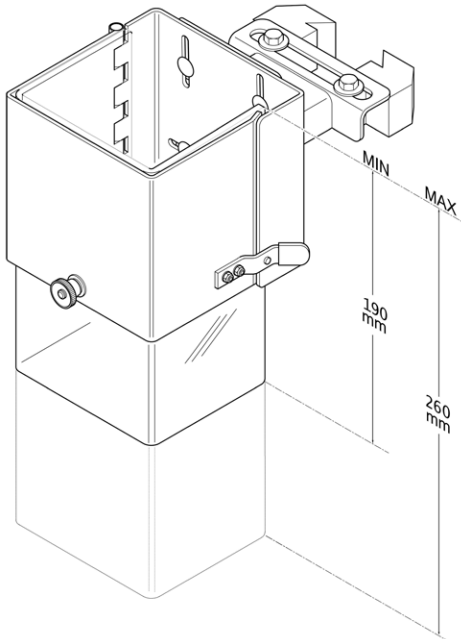

- Type of Pillar. Herbert or Pollard
- Dimension of Slot or Dovetail
- Manual or Interlocked

Our Guards

Drilling Machine

Universal Drill Guards - SV & TV

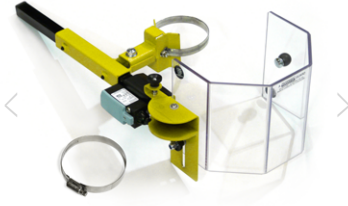

Model: SV

Product Details

- Suitable for ALL Drilling Machines
- High Torque Clip - Clamps guard directly to the Pillar
- Supplied with Fixing
- Clamp Range 50mm < 80mm or 80mm < 100mm
- SV - Single Adjustable Vizor
- TV - Double Adjustable Vizors
- Positive Locking
- Interlock Switching available - **See Interlock Technical P11.**

Complete Guards

Part No.	Model
20019	SV Guard
20020	SV Guard - Interlock
20021	TV Guard
20022	TV Guard - Interlock

Visors

Part No.	Model	Visor Size
20010	SV Body	190 x 150 mm
20011	SV Large	260 x 150 mm
20023	TV Body	190 x 150 mm
20024	TV Sliding	190 x 270 mm

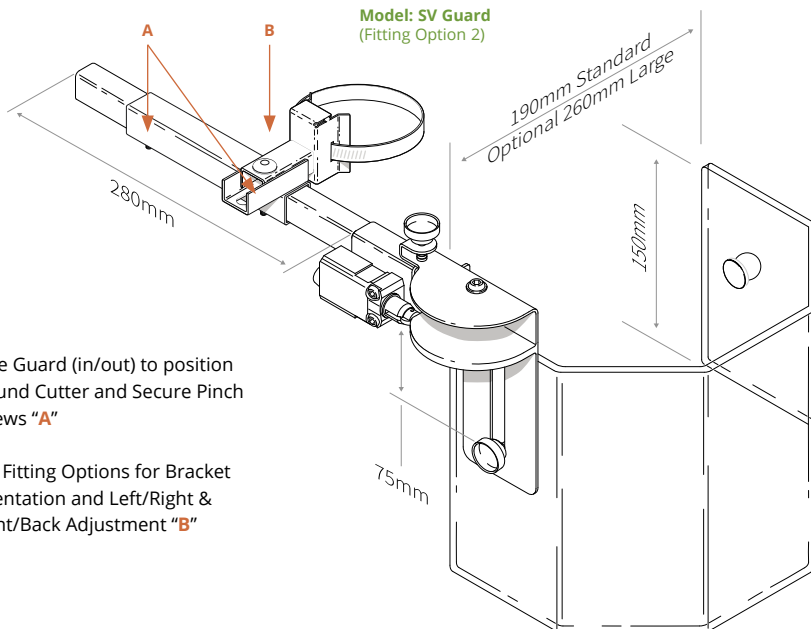

- Slide Guard (in/out) to position around Cutter and Secure Pinch Screws "A"
- See Fitting Options for Bracket Orientation and Left/Right & Front/Back Adjustment "B"

Drilling Machine Technical Data

Fitting Options - SV & TV

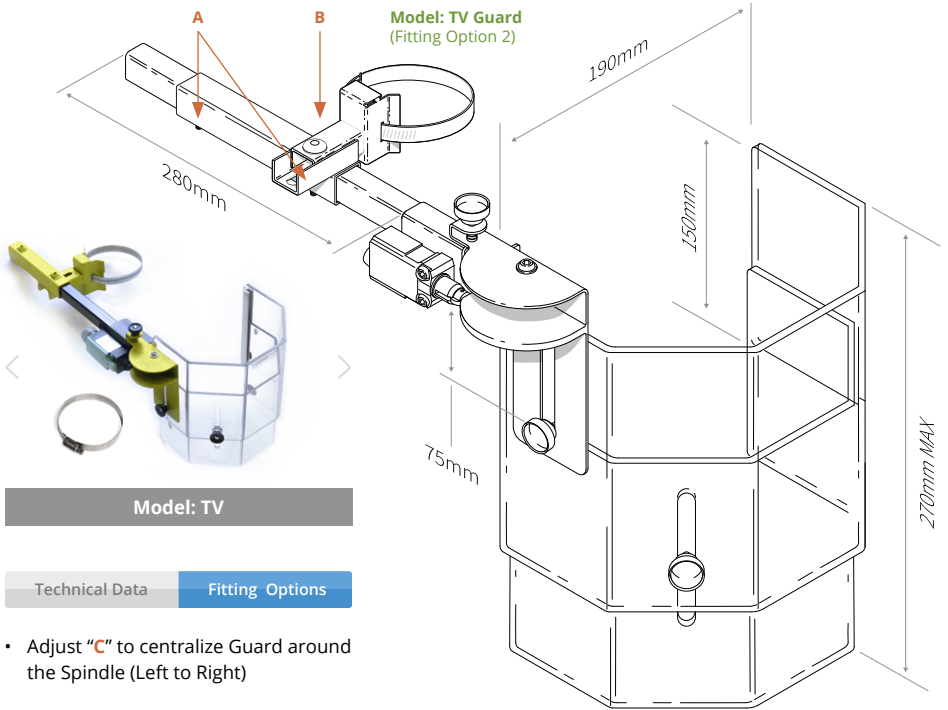

Technical Data Fitting Options

- Adjust "C" to centralize Guard around the Spindle (Left to Right)
- Orientate Bracket "D" to position Guard (Back to Front)

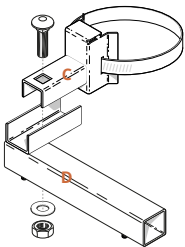

Fitting Option 1

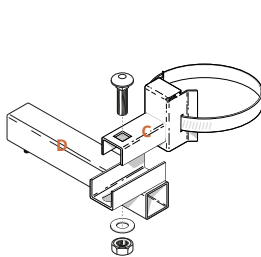

Fitting Option 2

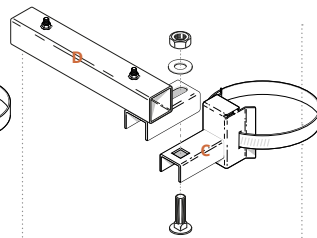

Fitting Option 3

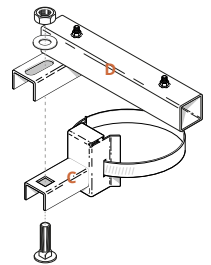

Fitting Option 4

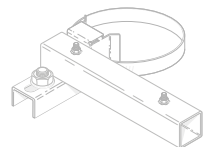
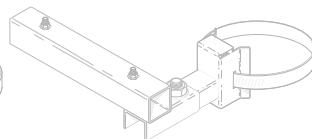
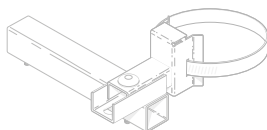
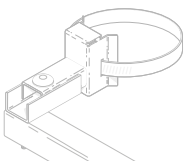

Our Guards

Milling Machine

Milling Machine Guards



Silvaflame-Cleervue manufactures a comprehensive range of milling machine guards to suit virtually all types and sizes of manual and CNC milling machines both horizontal & vertical including Cincinnati Beaver Mills, and all Bridgeport types.

CNC type are fitted with electrical interlock switches
See **Interlock Technical P11**.

Specially Designed Guards are also available

For further expert advice please contact us.

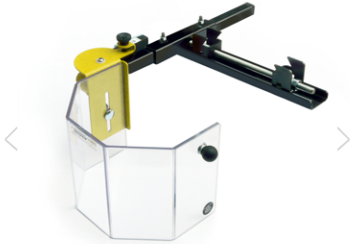

MILLING MACHINES

1. Manually Operated Milling Machine Cutter Guard
2. Universal Turret Millguard
3. Manually Operated Milling Machine Table Guard
4. Turret/Bed CNC Milling Machine Guard Hinge Type
5. Turret/Bed CNC Milling Machine Universal Guard Sliding Type
6. Horizontal Milling Machine Guard
7. Universal Milling Machine Guard
8. Multi Adjust Milling Machine Guard
9. Adjustable Milling Machine Guard
10. Horizontal Slide Milling Machine Guard
11. Safety Cap for Milling Machine Drawbar
12. TECDUR CNC Replacement Safety Glass

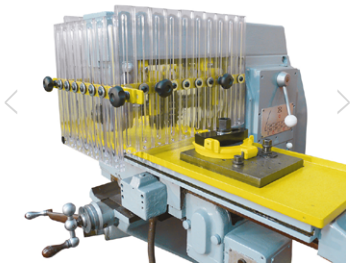

Our Guards

Milling Machine

Manually Operated Milling Machine Cutter Guard

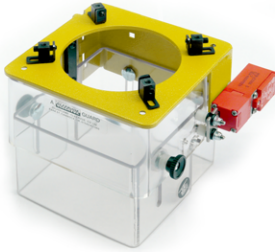

Model: MILLER CUTTER



Model: REAR SHIELD

Product Details

- Machine Type – Manually operated milling machines
- Method of attachment – By use of our unique fixing system which allows attachment to the miller head by means of pinch screws/bracket
- Accommodating heads up to 145mm diameter Spindles up to 105mm diameter
- Positive latching but may also be interlocked
- Construction – Moulded polycarbonate body, with 4mm thick adjustable visor to Enclose cutter/work area
- Interlock Switching available - **See Interlock Technical P11.**

Additional Safety Accessory is the adjustable Rear Shield which gives 360° enclosure to the Guard and is strongly recommended for ALL Educational Establishments.

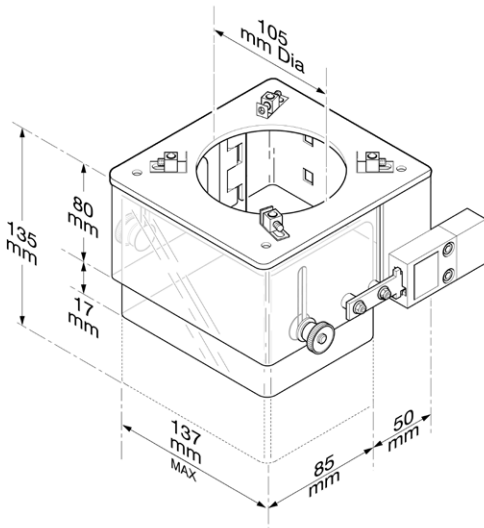

Miller Cutter Guard

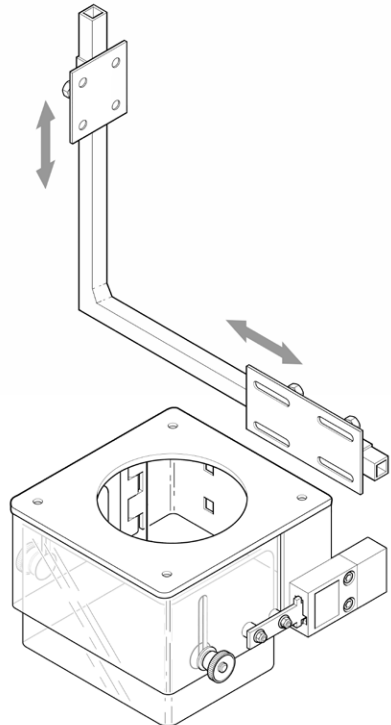

Miller Cutter Guard with Side Attachment

Rear shield not available on this model

Our Guards

Milling Machine

Universal Turret Millguard

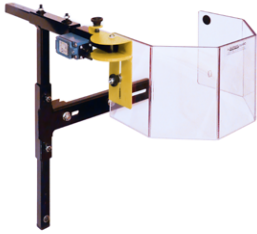

Product Details

- Suitable for all manual Turret Mills
- Method of attachment: Secures to Head 'V' slide or Vertical 'V' slide
- Adjustable Visor
- Positive latching but may also be Interlocked

See Interlock Technical P11.

Available as a Package Containing:

The main guard extension with the hinge lock arrangement and interlock switch, 2 different size interchangeable visors.

A 'V' slide clamp unit and the vertical 'V' slide adaptor bracket.

Model: UNIVERSAL TURRET GUARD

Additional Safety Accessory is the adjustable Rear Shield which gives 360° enclosure to the Guard and is strongly recommended for ALL Educational Establishments.



Guard to Mount on Head 'V' Slide with Rear Shield

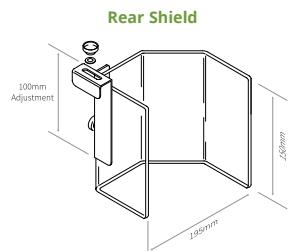
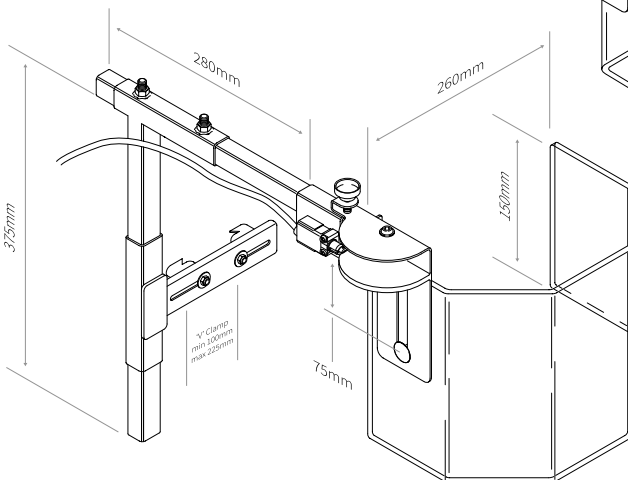
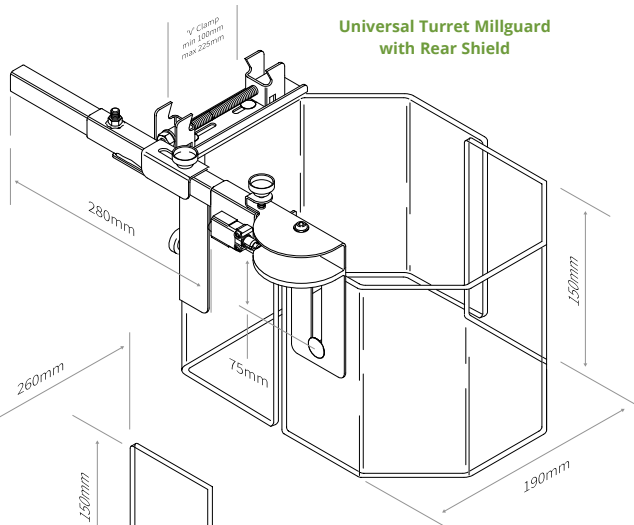

Our Guards

Milling Machine

Manually Operated Milling Machine Table Guard



Model: MAX-A-JUST

Product Details

- Machine Type - Manually operated Milling Machines
- Method of attachment - Adjustable rail secured to machine table with T. Nuts (1 per side)
- Positive Manual latch
- Construction - Mild steel adjustable polycarbonate visors
- Operation - Vizors adjusted around machine cutters, hinges open to give access to tooling (Interlock NOT available)

Part No.	Model
20001	MAX-A-JUST M1
20002	MAX-A-JUST M2

Spare Visors (Set of 6)

Part No.	Model
20003	MAX-A-JUST M1
20004	MAX-A-JUST M2

-	MAX-A-JUST M1	MAX-A-JUST M2
Minimum Vertical Height	200mm	250mm
Maximum Vertical Height	350mm	450mm
Minimum Overall Length Enclosing	375mm	475mm
Maximum Overall Length Enclosing	525mm	800mm
Minimum Overall Length Extended	700mm	925mm
Maximum Overall Length Extended	875mm	1250mm

Both Sides Extended In-Line / Smallest T-Nut available 12mm / Largest T-Nut available 18mm

Manually Operated Milling Machine Table Guard MAX-A-JUST

IMPORTANT:
WHEN ORDERING
PLEASE SPECIFY
'TEE SLOT' SIZE

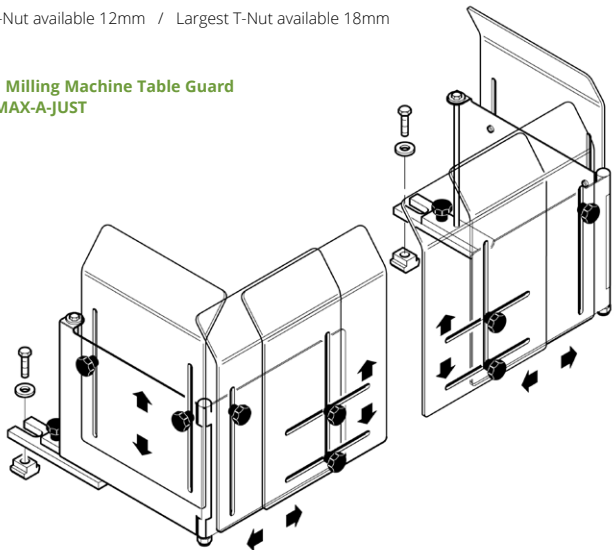
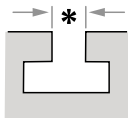

Our Guards

Milling Machine

Turret/Bed CNC Milling Machine Guard Hinge Type



Model: EM GUARD

Product Details

- Machine Type - Turret/Bed CNC
- Method of attachment - Is by Adjustable Parallel Rails which are T Bolted to Table Slots allowing the Guard to be positioned forward around Vice or Component
- Twin Interlock and Positive Manual Latch
- Construction - Steel Tubular Frame and 5mm Polycarbonate Windows
- Type T has Additional Sliding Windows to give access to Turret or Machine Console

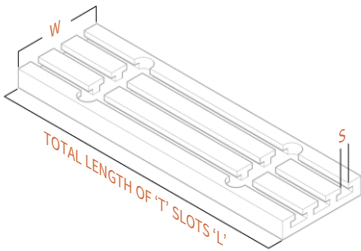

Optional Extras

- An Infill Swarf Tray is available to reduce the hazard of fallen Swarf
- Rear Swarf Shield - Helps to contain the flying Swarf within the table area and also act as a deterrent against third party intervention from the rear.
- Operation - Totally encloses front and side of machine table. Rear hinged to give access to complete table area when in open position

How to Measure Machine Table

Part No.	Guard	MIN Table Size	Max Table Size	Front Window Size	Side Window Size
80002	EM/1	945mm	1000mm	2 - Dedicated to table Length x 460mm Height	2 - 500mm x 460mm
80003	EM/3	1000mm	1500mm	2 - Dedicated to table Length x 460mm Height	2 - 500mm x 460mm
80050	EM3/T Sliding Window Type	1000mm	1500mm	2 - Dedicated to table Length x 460mm Height	2 - 500mm x 460mm

Other Table Lengths are available - Details & Price on application

Our Guards

Milling Machine

EM Guard

Shown with Swarf Tray and Shield

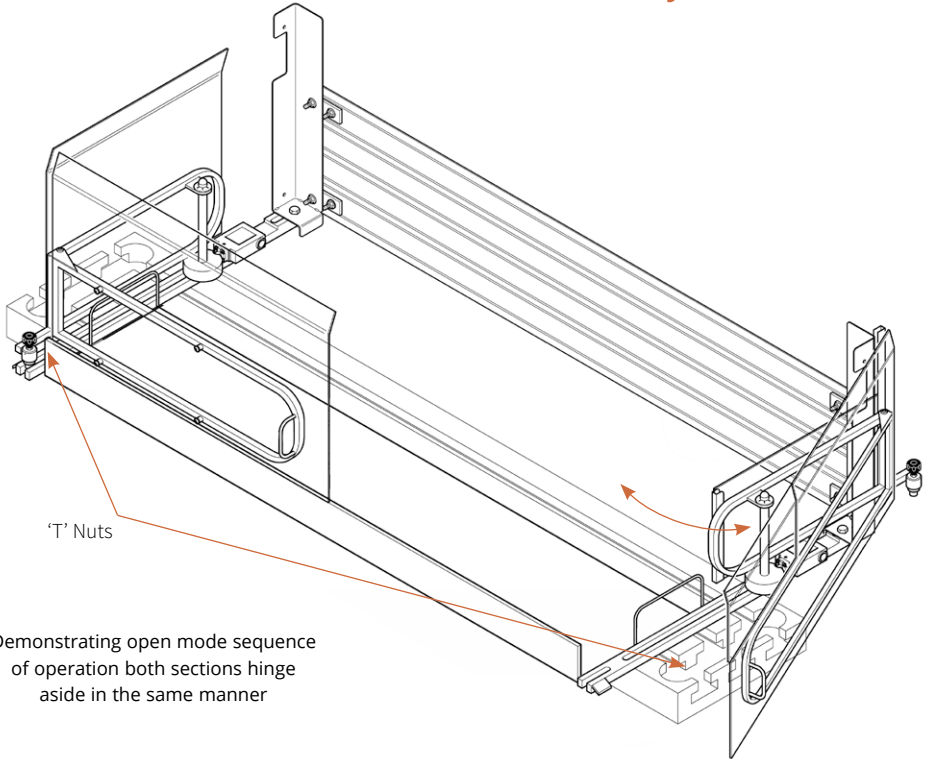

Demonstrating open mode sequence of operation both sections hinge aside in the same manner

Ordering Information

To ensure you receive the correct guard for your requirements state Model Number required and specify Dimension L, Dimension W Table Width and Dimension S

Optional Extras

Swarf Tray and Back Shield

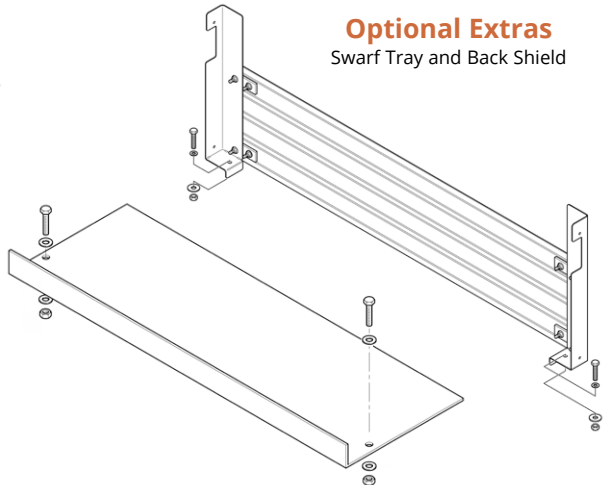

93/1844

Our Guards

Milling Machine

Turret/Bed CNC Milling Machine Guard Sliding Type



Model: SSP GUARD

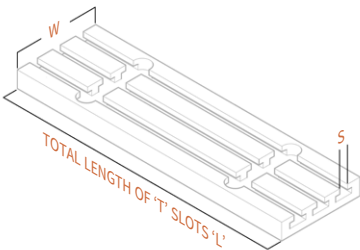

How to Measure Machine Table

Product Details

- Method of attachment - Is by Adjustable Parallel Rails which are T Bolted to Table Slots allowing the Guard to be positioned forward around Vice or Component
- Single Interlock and Positive Manual Latch
- Construction - Steel Tubular Frame and 5mm Polycarbonate Windows

Optional Extras

- An Infill Swarf Tray is available to reduce the hazard of fallen swarf
- Rear Swarf Guard - Helps to contain the flying swarf within the table area and also act as a deterrent against third party intervention from the rear.

(We no longer produce the rigid type shown in our photograph. It has now been updated with a Flexible Shield)

- Operation - Totally encloses front and side of machine table. Slide and fold back front windows giving access to the work area. Hinged side windows to expose both end of machine table to allow machining of components that extend beyond table length. The right hand side of guard has additional sliding windows to give access to turret or machine console.

-	Maximum Table Size	Minimum Table Size	LEFT-HAND Side Window	RIGHT-HAND Side Window	FRONT RIGHT-HAND Sliding Window
SSP2	1585	940mm	500mm x 460mm	500mm x 460mm Max Adj to 275 Min	320mm x 222mm Ht.



93/1844

Ordering Information

To ensure you receive the correct guard for your requirements state Model Number required and specify Dimension L, Dimension W Table Width and Dimension S

Our Guards

Milling Machine

SSP Guard

Shown with Swarf Tray and Shield

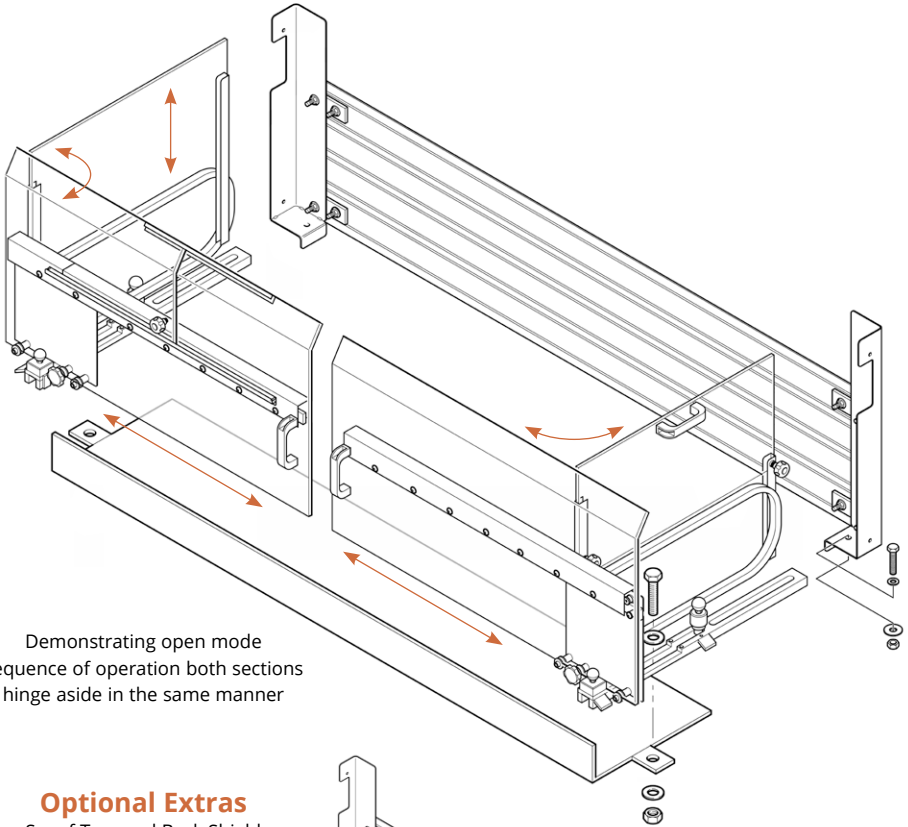

Demonstrating open mode
sequence of operation both sections
hinge aside in the same manner

Optional Extras

Swarf Tray and Back Shield

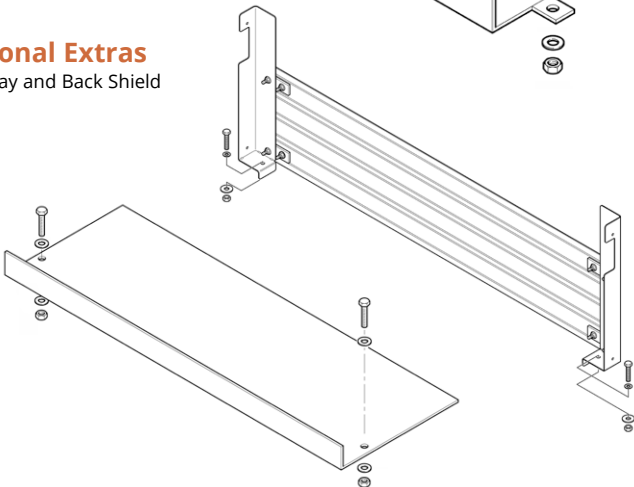

Our Guards

Milling Machine

Horizontal Milling Machine Guard



Model: HORIZONTAL GUARD

Product Details

- Machine Type - Horizontal Milling Machines
- Method of attachment - Secures to Overarm with V Brackets or A or B Clips
- Manually adjusted (Tool provided)
- Construction - Mild Steel adjustable Interlocking 6 mm Polycarbonate Visors
- Operation - Vizors adjust around Machine to allow entrance for work piece only (Interlock NOT available)

Standard Model - Viewed from above

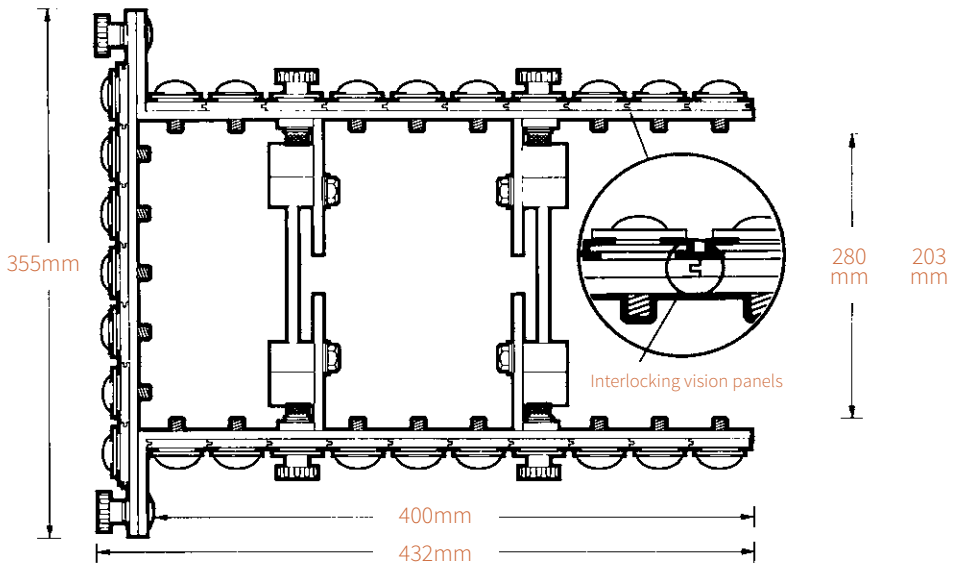

Ordering Information

1. Type of overarm
2. Size of clips or dovetail

Type A
Single Overarm

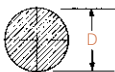

Type B
Double Overarm



Type C
Vee Slide

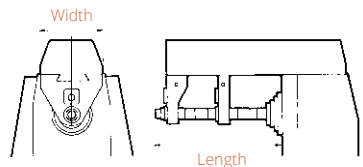

We can manufacture other sizes, to enable us to quote please send details of width and length of guard required as illustrated.

Our Guards

Milling Machine

Universal Milling Machine Guard



Model: PFR 01

Complete Guards

Part No.	A - Width	B - Height	Weight
PFR 01/300	300 mm	200 mm	9,5kg
PFR 01/400	400 mm	235 mm	9,8kg
PFR 01/500	500 mm	235 mm	10,1 kg
PFR 01/600	600 mm	235 mm	10,4kg

Construction

- 1 Levelling Anchorage Stirrup in Tubular Steel
- 2 Depth Adjustable safety Guard Support
- 3 Safety Microswitch Main Box - 180° Rotation
- 4 Horizontal Adjustment Clamp
- 5 Articulated Arms in Tubular Steel
- 6 Rubbing Articulation with Friction Disc
- 7 Shield Arm Connection Clamp in Pressed Steel
- 8 Shield Structure in Tubular Steel
- 9 Thermo Formed Shield - Shockproof and Oil Resistant

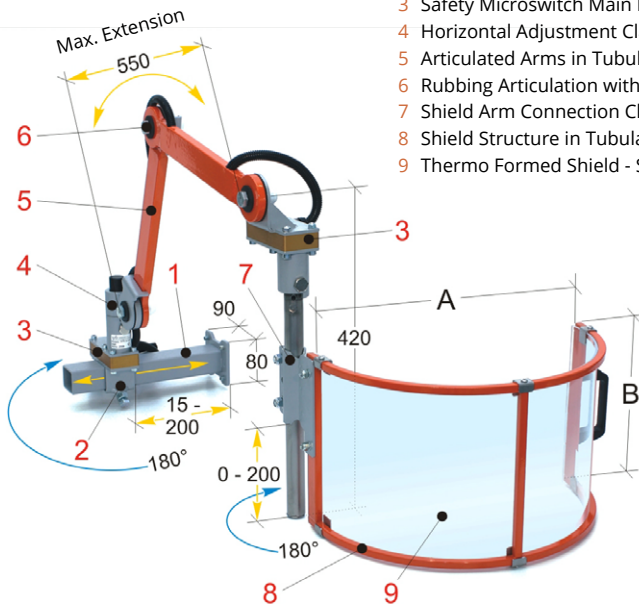

93/1844

PFR 01 - Universal Milling Machine Guard

- Machine Type - Conventional & CNC Milling Machines (Horizontal & Vertical)
- Method of attachment - Secures to Machine Side
- Wide Visibility Polycarbonate Screen
- Tubular Steel Levelling Mount Bracket
- Fully Adjustable including Horizontal Adjustment Clamping with Dual Opening System
- Can be Lifted Up or Swung to the Side
- Supplied with Double Safety Microswitch - Conforming to EN 1008

Our Guards

Milling Machine

Multi Adjust Milling Machine Guard

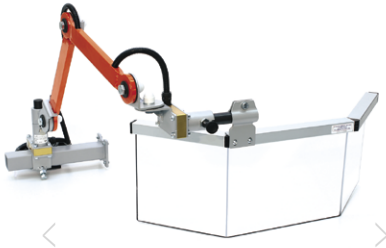

Model: PFR 02

Complete Guards

Part No.	A	B	C	D	Weight
PFR 02/625	620	250	170	405	10,4kg
PFR 02/730	725	300	200	430	10,9kg

Construction

- 1 Levelling Anchorage Stirrup in Tubular Steel
- 2 Depth Adjustable Safety Guard Support
- 3 Safety Microswitch Main Boxes 180° Rotation
- 4 Horizontal adjustment clamp
- 5 Articulated Arms in Tubular steel
- 6 Rubbing Articulation with Friction Disc
- 7 Angular Junction for the Vertical Turnover of the Shield
- 8 Shield Opening Unlocking Knob
- 9 Shield Structure in Aluminium Profile
- 10 Shield - Shockproof and Oil Resistant

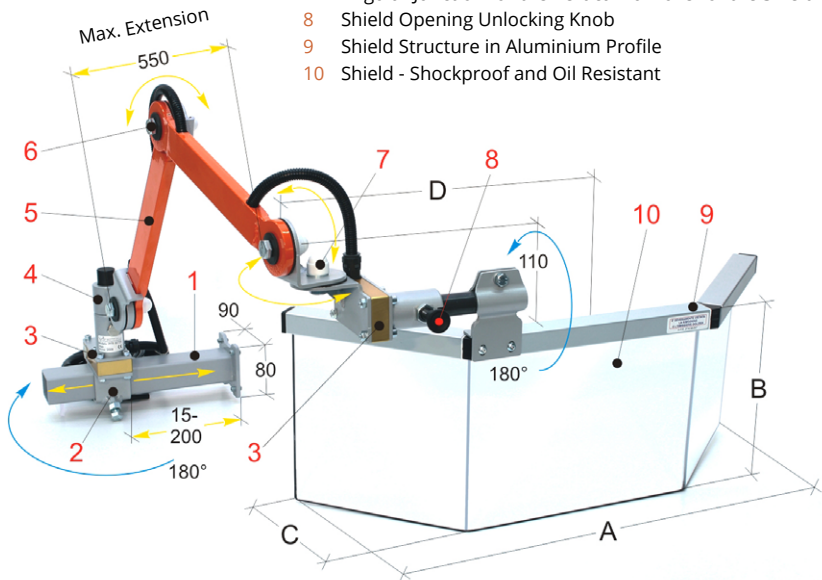

PFR 02 - Universal Milling Machine Guard

- Machine Type - Conventional & CNC Milling Machines (Horizontal & Vertical)
- Method of attachment - Secures to Machine Side
- Wide Visibility Polycarbonate Screen
- Tubular Steel Levelling Mount Bracket
- Fully Adjustable including Horizontal Adjustment Clamping with Dual Opening System
- Can be Lifted Up or Swung to the Side
- Supplied with Double Safety Microswitch - Conforming to EN 1008

Our Guards

Milling Machine

Adjustable Milling Machine Guard



Model: PFR 04

Complete Guards

Part No.	A - Width	B - Height	Weight
PFR 04/400	400 mm	235 mm	9,8kg
PFR 04/500	500 mm	235 mm	10,1kg
PFR 04/600	600 mm	235 mm	10,4kg

Construction

- 1 Levelling Anchorage Stirrup in Tubular Steel
- 2 Depth Adjustable safety Guard Support
- 3 Safety Microswitch Main Box - 180° Rotation
- 4 Horizontal Adjustment Clamp
- 5 Articulated Arms in Tubular Steel
- 6 Rubbing Articulation with Friction Disc
- 7 Shield Arm Connection Clamp in Pressed Steel
- 8 Shield Structure in Tubular Steel
- 9 Thermo Formed Shield - Shockproof and Oil Resistant

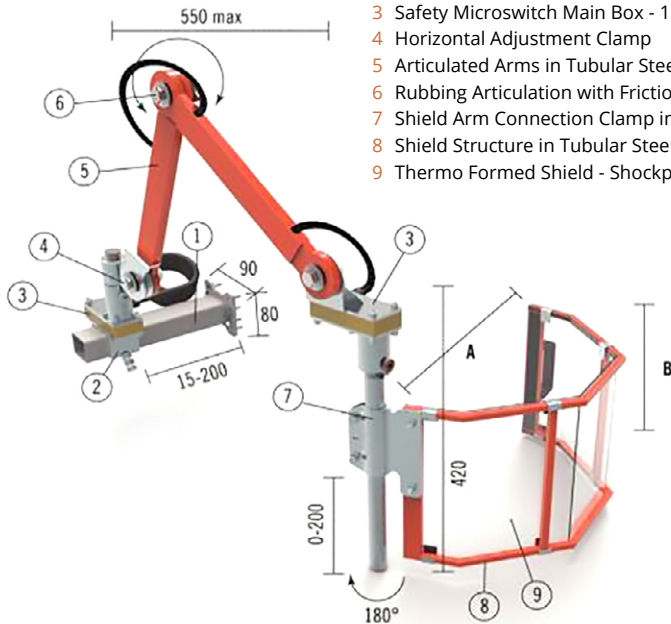

93/1844

PFR 04 - Adjustable Milling Machine Guard

- The PFR 04 Mill Guard Protects the Operator from direct contact with Rotating Parts of the spindle and airborne debris and coolant from machine
- The PFR 04 is a Universal Safety Guard with Articulated Arms. The friction joints make it particularly versatile
- The PFR 04 Affixes to the side of the Machine and is equipped with two points of interlocked movement
 - 1) Screen Opening.
 - 2) Complete Opening for loading
- This Milling Machine Guard comes complete with Double Safety Microswitch
- Do not disrupt the operators work flow whilst maintaining maximum safety at all times
- Machine Guards are in conformance with P.U.W.E.R (1998) and come with a Certificate of Conformity

Our Guards

Milling Machine

Horizontal Slide Milling Machine Guard



Model: PFR 10

Complete Guards

Part No.	A	B	C	Weight
PFR 10/420	400 mm	200 mm	830 mm	8,5kg
PFR 10/430	400 mm	300 mm	830 mm	8,8kg
PFR 10/530	500 mm	300 mm	930 mm	9,1kg

Construction

- 1 Adjustable Angular Stirrups, for Microswitch Box Anchorage and support of the Horizontal Arm - in Pressed Steel
- 2 Safety Microswitch Main Box 180° Rotation
- 3 Horizontal Shield support Arm in Tubular Stainless Steel
- 4 Aluminium Fixing Clamps for adjustment of the Shield
- 5 Shield - Shockproof and Oil-Resistant

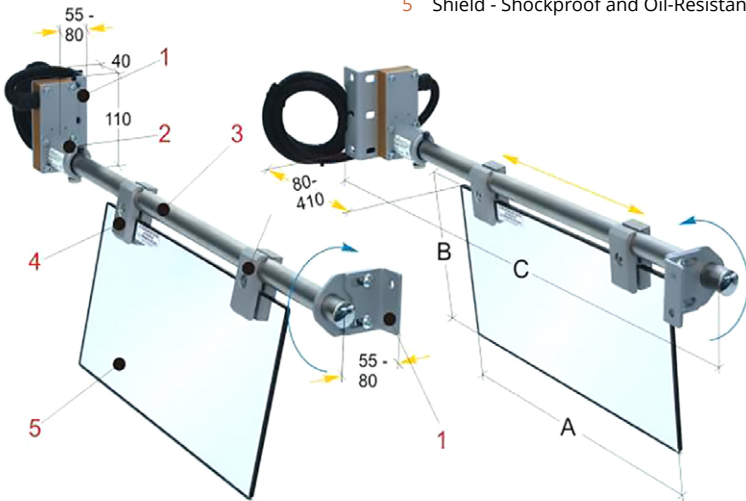

93/1844

PFR 10 - Horizontal Slide Milling Machine Guard

- The PFR 10 Protects Operator from Direct Contact with the Horizontal Shaft, Airborne Debris and Coolant
- Comes with Two Screens, made of Top Quality Polycarbonate giving excellent visibility
- The Screens can be Profiled to suit the Equipment in use if needed
- Guard is attached to Two Sides of the Machine
- The Guard is Adjustable in a Circular and Linear Manner
- Comes complete with Double Safety Microswitch conforming to EN 1088
- Do not disrupt the Operators Work flow whilst Maintaining Maximum Safety at all times
- Machine Guards are in Conformance with P.U.W.E.R (1998) and come with a Certificate of Conformity

Our Guards

Milling Machine

Safety Cap for Milling Machine Drawbar

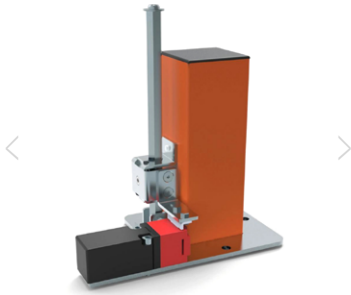

Model: PFR 05/170

Complete Guards

Part No.	A	B	C
PFR 05/170	193 mm	120 mm	172 mm

Construction

- 1 Fixing Plate
- 2 Safety Microswitch with Separated Actuator
- 3 Crankcase
- 4 Crankcase Support Stirrup
- 5 Hexagonal Sliding Rod
- 6 Microswitch Key Support

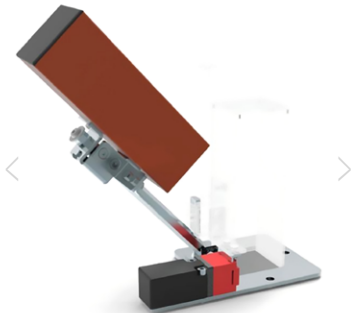

Model: PFR 05/170

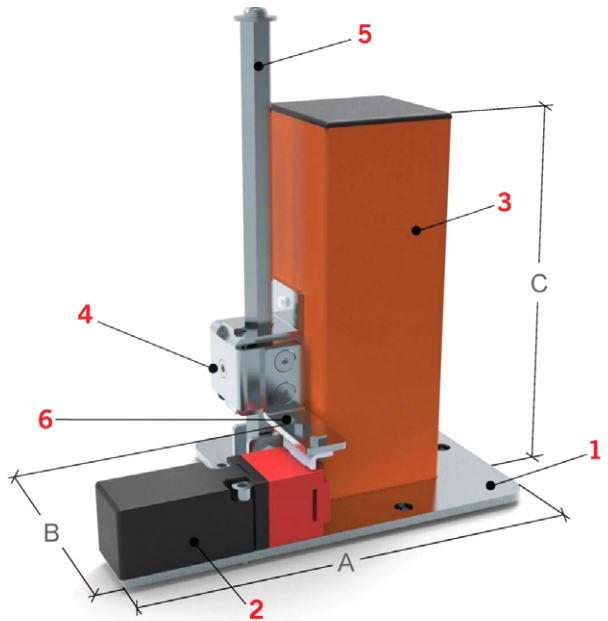

PFR 05 - Safety Cap for Milling Machine Drawbar

- Safety Guard for Upper and Rear Milling Machine Drawbar, with Tied Opening/Closing Movements
- Equipped with Pre-Drilled Flange for easy installation
- Opening protected by Safety Microswitch and Screw Locking

Our Guards

Milling Machine

TECDUR CNC Replacement Safety Glass



CNC Machine Safety Glass

TECDUR CNC Replacement Safety Glass

- TECDUR MachineSafe is a range of CNC Machine Safety Glass
- These MachineSafe Windows are designed for use in CNC Machining Centres, Lathe, Milling and other Metalworking Machines that require specialist Machine safety windows
- TECDUR MachineSafe provides protection of the Polycarbonate layer from ageing by using a Fully Laminated System
- By replacing existing CNC Vision Panels with TECDUR MachineSafe, the potential for downtime is reduced
- The Vision Panels are manufactured to the latest BS EN ISO Standards to meet the Machine Window Specification and Safety Rating

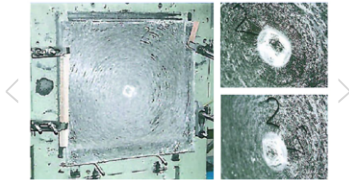

CNC Machine Safety Glass

TO ACCURATELY QUOTE, WE NEED:

**Make and Model of Machine
Window Length
Width and Thickness**

Please contact us, we will be happy to help



CNC Machine Safety Glass

Our Guards

Lathe Guards

Lathe Guards



It is a legal requirement under EN:23125:2010 to fit an Interlock Guard to protect the operator from coming into contact with the rotating parts of the lathe.

A comprehensive range of lathe chuck guards to suit most types and sizes of lathe including DSG, Harrison, Crawford Swift, Colchester & TOS Lathes are manufactured by Silvaflame with electrical interlock systems.

Specially designed lathe guards are also available. Please use our contact form to request further information.

Silvaflame-Cleevue can provide solutions to your lathe guarding requirements including hinged chuck guards, traversing guards, leadscrew covers and chip guards.

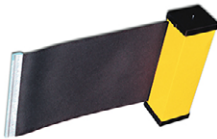

LATHE

1. Light to Medium Centre Lathe Chuckguard
2. Light to Medium Centre Lathe Traversing Guard
3. Securvue Sliding Lathe Chuckguard Range
4. PTO 01 Lathe Chuck Guard
5. PTO 02 Lathe Machine Guard
6. Leadscrew Covers



93/1844

Our Guards

Lathe Guards

Light to Medium Centre Lathe Chuckguard



Model: L6

Product Details

- Machine Type - Light to Medium Centre Lathes
- Method of attachment - Secures to Face or Top of Lathe Headstock
- Manually adjusted to Cover Work Area. Interlocked
- Cast aluminium and 4 mm Polycarbonate Visors
- L12 - Mild Steel, P.V.C. Skirt, 6.6 Nylon Pivot Bushes and 4mm Polycarbonate Visors
- Hinges to allow access to Chuck and Work Area

Part No.	Model	Spare Visors (Set)	Max Chuck Dia	Width A	TOP Length B	SIDE Length C
100001	L6	-	150mm	175mm	175mm	175mm
100003	L12	-	300mm	215mm	260mm	232mm
100005	L18	-	450mm	265mm	350mm	350mm
100002	-	L6	-	-	-	-
100004	-	L12	-	-	-	-
100006	-	L18	-	-	-	-



Model: L12



Model: L18

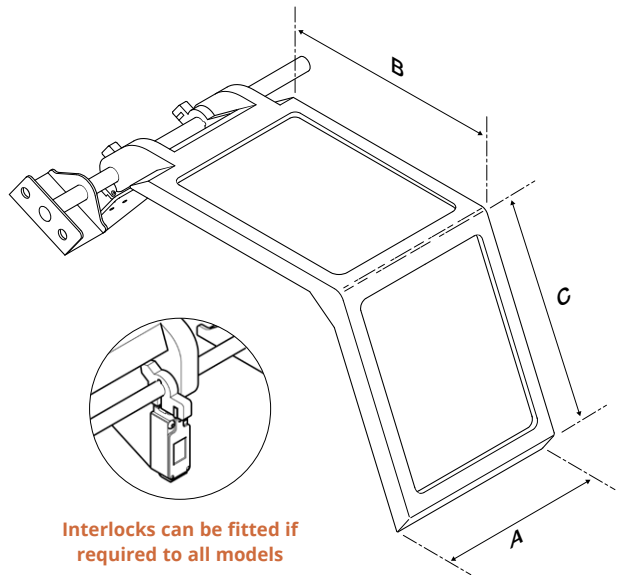

Interlocks can be fitted if required to all models

Our Guards

Lathe Guards

Light to Medium Centre Lathe Traversing Guard

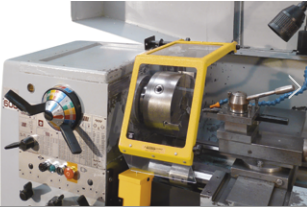

Model: TRAVERSING GUARD

Product Details

- Machine Type - Light to Medium Centre Lathes
- Method of attachment - Secures to Lathe Saddle
- Manually adjusted to Cover Work Area
- Cast Aluminium and 4 mm Polycarbonate Visors L6 & L18
- SL12 - Mild Steel, P.V.C. Skirt, Nylon Pivot Bushes and 4mm Polycarbonate Visors
- Traverses with Saddle Hinges to allow access to Chuck and Work Area

Part No.	Model	Spare Visors (Set)	Max Chuck Dia	Rod Length A	Rod Length B
100011	SL6	-	150mm	335mm	510mm
100007	SL12	-	300mm	335mm	510mm
100009	SL18	-	450mm	335mm	510mm
100012	-	SL6	-	-	-
100008	-	SL12	-	-	-
100010	-	SL18	-	-	-

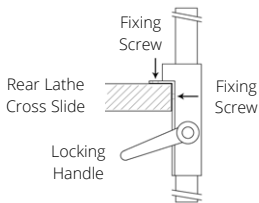

Model: SL12

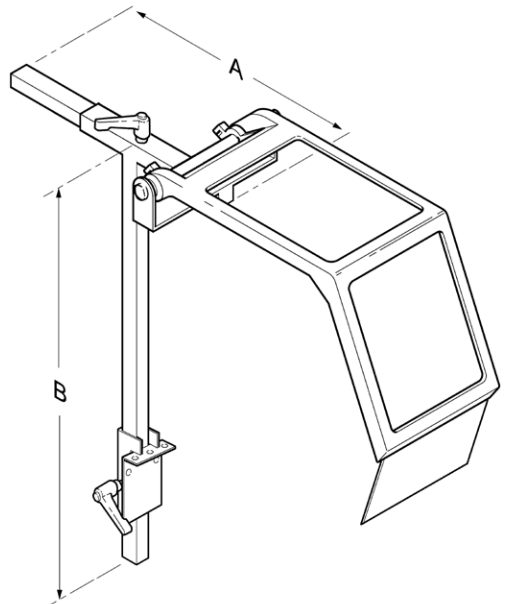

Our Guards

Lathe Guards

Securvue Sliding Lathe Chuckguard Range

Product Details

- Machine Type - Large/Heavy
- Method of Attachment - Secures by Adjustable Brackets to Top of Lathe Headstock Interlocked
- Construction - Mild Steel Frame sliding on Ball Bearing Track with 4mm Polycarbonate Visors
- Operation -Sliding action from Headstock to Enclose Chuck and Work Area



Model: SA-1

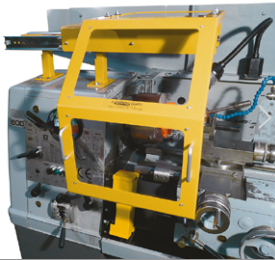

SA Lathe Guards

Part No.	Model	Description	Chuck Ø
10200	SA-1E	Lathe Chuckguard with Interlocks	Up to 600mm
10010	SA-1/V	Spare Window Set of Three	-

Part No.	Model	Description	Chuck Ø
80025	SA-2E	Lathe Chuckguard with Interlocks - Triple Track	1000mm
80026	SA-2/V	Spare Window Set of Three	-

Part No.	Model	Description	Chuck Ø
80027	SA-3E	Lathe Chuckguard with Interlocks - Triple HD Track	1500mm

CHUCK Ø IS FOR GUIDANCE ONLY

Support Configuration can be Manufactured to Suit Individual Machines



93/1844

Our Guards

Lathe Guards

Securvue Sliding Lathe Chuckguard Range

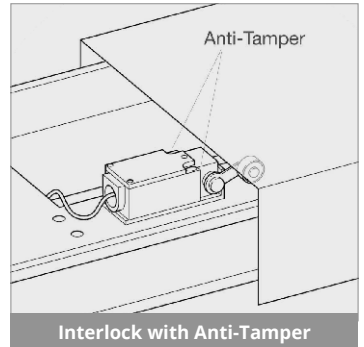
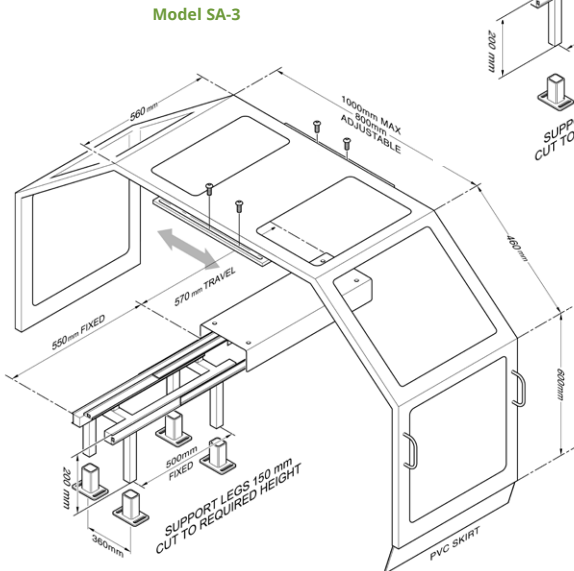
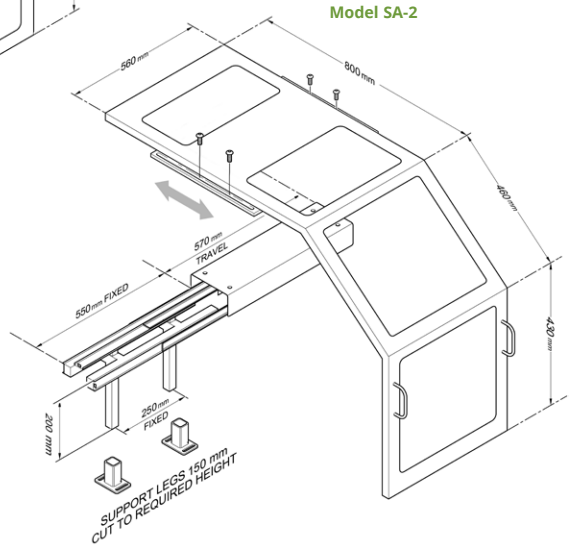
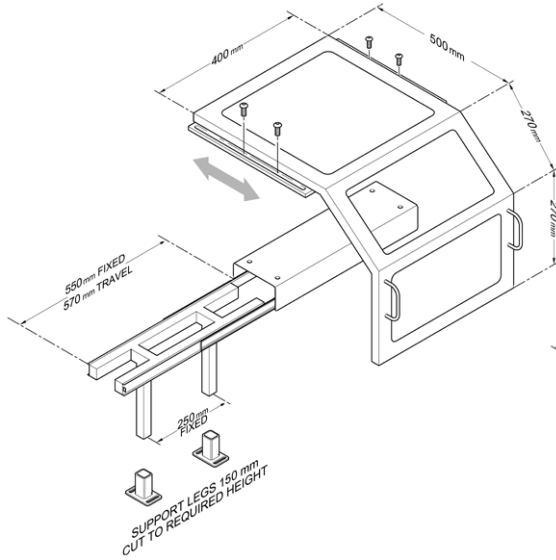

Our Guards

Lathe Guards

PTO 01 - Lathe Chuck Guard

Complete Guards



Part No.	A	B	C	D
PTO 01/300	300mm	200mm	180mm	0-215mm
PTO 01/400	400mm	235mm	230mm	0-150mm
PTO 01/500	500mm	235mm	280mm	0-150mm
PTO 01/600	600mm	235mm	330mm	0-150mm

Model: PTO 01

Construction

- 1 Frontal and Lateral Anchorage Stirrup
- 2 Safety Microswitch Main Box - 90° Rotation
- 3 Shield Connection Clamp with Support Arm - in Pressed Steel
- 4 Shield Structure in Tubular Steel
- 5 Thermo-Shaped Shield - Shockproof and Oil-Resistant

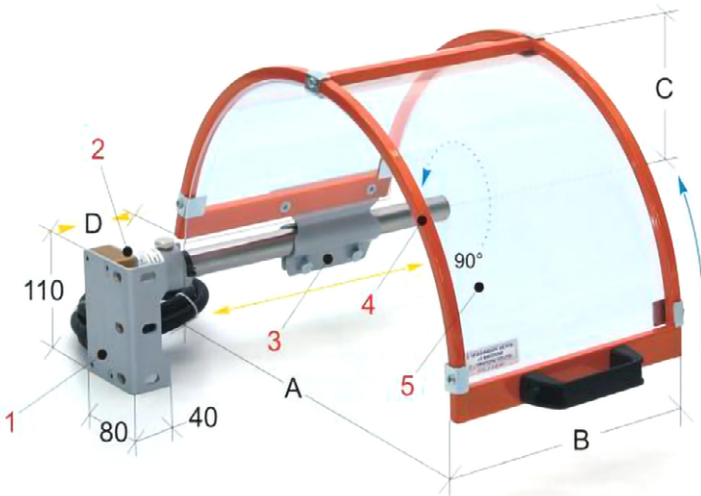

93/1844

PTO 01 - Lathe Chuck Guard

- The PTO 01 Lathe Chuck Guard Protects from the Upper part of the Chuck and from Coolant Spray
- Can be attached to the Base from the Front or the Side
- Equipped with a Steel and Polycarbonate Semicircular Shield
- Polycarbonate Build ensuring Resistance to High Impact and Excellent Visibility
- Adjustable for a Close Fit to the Head Stock
- Complete with Safety Microswitch Conforming to EN 1088
- All Machine Guards are in Conformance with P.U.W.E.R (1998) and come with a Certificate of Conformity

Our Guards

Lathe Guards

PTO 02 - Lathe Machine Guard

Complete Guards

Part No.	A	B	C	D
PTO 02/300	300mm	200mm	200mm	0-200mm
PTO 02/400	400mm	220mm	250mm	0-190mm

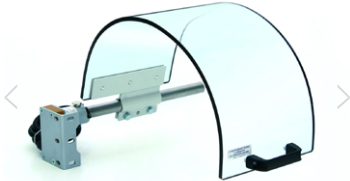

Model: PTO 02

Construction

- 1 Frontal and Lateral Anchorage Stirrup
- 2 Safety Microswitch Main Box - 90° Rotation
- 3 Adjustable Shield Connection Clamp with Support Arm in Pressed Steel
- 4 Monolithic Shield - Shockproof and Oil-Resistant

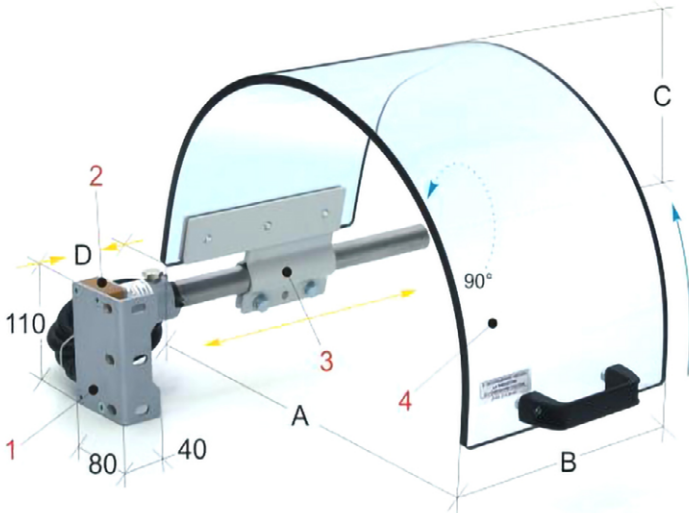

93/1844

PTO 02 - Lathe Chuck Guard

- Can be Attached to the Base from the Front or the Side
- The PTO 02 Protects from contact with the Upper Part of the Chuck and from Coolant Spray
- Equipped with a Steel and Polycarbonate Semicircular Shield
- Top quality Polycarbonate Build ensuring Resistance to High Impact and Excellent Visibility
- Adjustable for a Close Fit to the Head Stock
- Complete with Safety Microswitch Conforming to EN 1088
- Guards do not disrupt the operators work flow whilst maintaining maximum safety at all times

Our Guards

Lathe Guards

Leadscrew Covers



Model: LEADSCREW COVER

Product Details

- All Steel Box
- Swarf & Cutting Emulsion Resistant
- Standard Brackets Supplied
- Overall Length of Bed and Width of Shafts is Required
- Maximum Length 2500mm

Manufactured with a Steel Casing, the Guard uses Heavy Weight Neoprene Nylon as its Sheet Medium, Sprung to give a Full Closure against the Leadscrew, therefore offering Full Protection for the operator.

ADDITIONAL FIXING BRACKETS MAY BE NEEDED

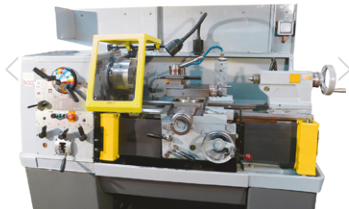

Model: LEADSCREW COVER

Part No.	Description
70006	Leadscrew Roller Cover x Overall Length of Bed



Model: LEADSCREW COVER

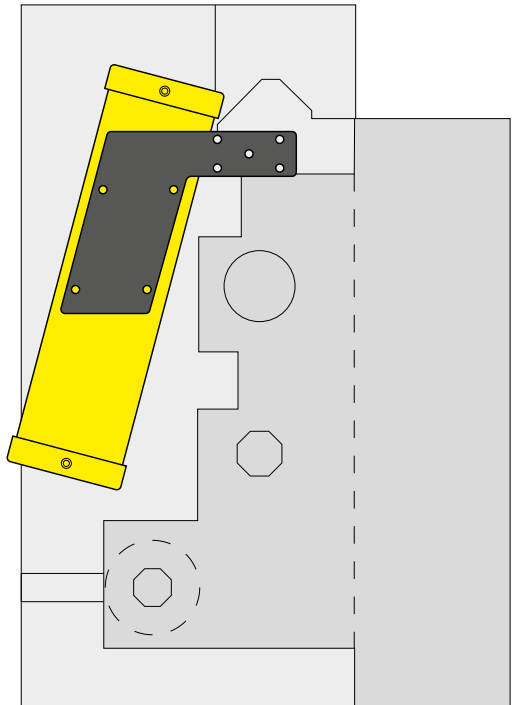

Our Guards

Magnetic Guards

Magnetic Guards



Silvaflame-Cleervue manufacture a range of ancillary machinery products including magnetic guards, anti-splash screens, emergency braking and stop systems and clamping components.

In addition to our standard guard range we can also design and produce bespoke guards for special purpose machinery such as Borer, Lathes, CNC and Robotics.

MAGNETIC GUARDS

1. Magnetic Optiguards Eye Protection
2. Magnetic Guard with Flexible Arm
3. Machine Guard with Magnetic Base



93/1844

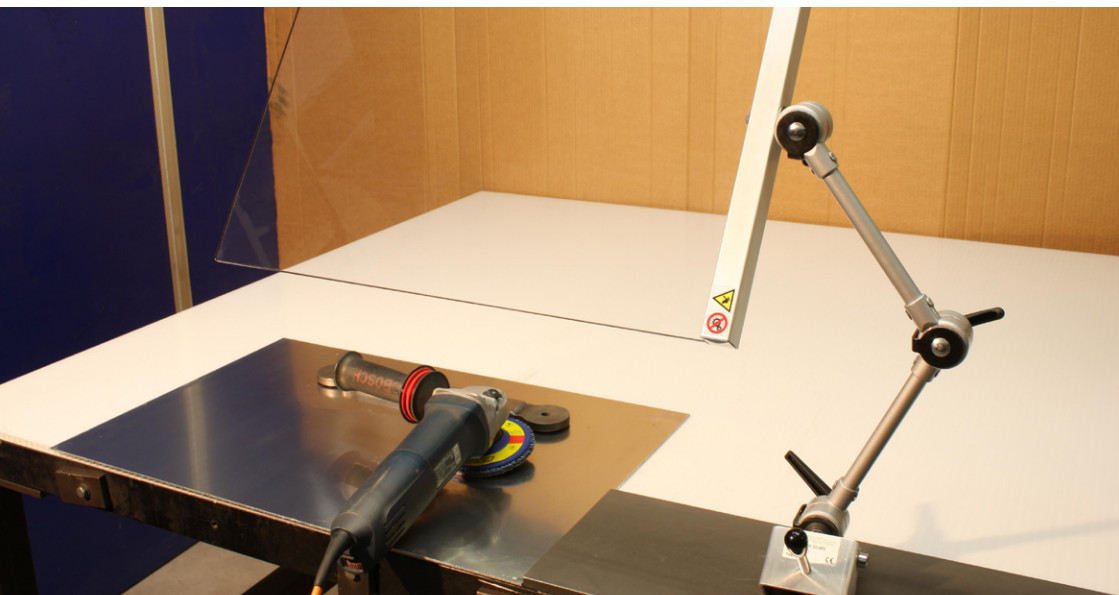

Our Guards

Magnetic Guards

Magnetic Optiguards Eye Protection



Model: 001 & 03



Model: 01 & 05



Magnetic Operation

Product Details

- Machine Type - Variable machines.
- Type of attachment - On/off magnet.
- Manually adjusted.
- Construction - 3 mm Polycarbonate vizor.
- Operation - Eye protection.
- **Models 01 and 05** have a flat screen with top curvature and are attached to a on/off magnet by a flexible stem which enables the screen to be rapidly positioned at any angle.
- **Models 00-1 and 03** have the same type of screen and are attached to a powerful on/off magnet by a rigid arm with precision ball and socket mounting assembly enabling the screen to be positively adjusted and locked in any position.

Complete Guards

Part No	Model	Screen Size	Type of Stem
110001	01	245mm x 180mm	Flexible
110009	05	295mm x 280mm	Flexible
110005	00-1	245mm x 180mm	Ball Joint
110003	03	295mm x 280mm	Ball Joint

Spare Screens Only

Part No	To Suit	Size
110002	01	245mm x 180mm
110010	05	295mm x 280mm
110006	00-1	245mm x 180mm
110004	03	295mm x 280mm



Our Guards

Magnetic Guards

PBM 10/11 - Magnetic Guard with Flexible Arm



Model: PBM 10/11

Model PBM 11

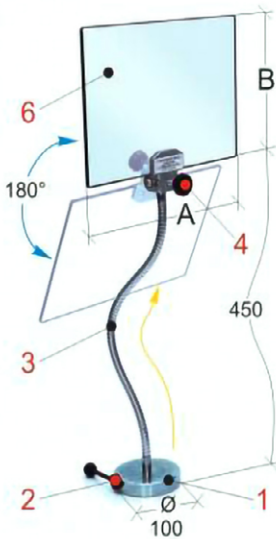

Complete Guards

Part No.	A	B	Weight
PBM 10/325	350mm	250mm	1.6kg
PBM 11/325	350mm	250mm	1.6kg

Construction

- 1 Magnetic Base with a Circumference of 100mm Force of Attraction 55kg
- 2 Eccentric Disconnection Lever
- 3 Flexible Articulated Arm
- 4 Shield Support Clamp equipped with Articulated Joint and Locking Knob (PBM 11)
- 5 Shield Support Clamp without Joint (PBM 10)
- 6 Shield - Shockproof and Oil-Resistant

Model PBM 10



93/1844

PBM 10/11 - Magnetic Guard with Flexible Arm

- Extremely Versatile and Available in Two different Versions
- Either Guard comes Equipped with an Extremely Powerful Attaching Magnet
- The PBM 10 and PBM 11 Protect the Face from the Projection of Emery, Dusts and Particles
- Guards come with an Accentuated Disconnect Button
- Both Guards are Extremely Adjustable:
 - The PBM 10/ Uses a Flexible Arm
 - The PBM 11/ Uses an Articulated Joint and a Flexible Arm
- Guards can be used on Machine Bases and Steel Work Surfaces
- Guards are Easy to Install and can be used for a Variety of Operations

Our Guards

Magnetic Guards

PBM 30 - Machine Guard with Magnetic Base



Complete Guards

Part No.	A	B	Weight
PBM 30/440	400mm	400mm	2.2kg
PBM 30/450	400mm	500mm	2.3kg
PBM 30/540	500mm	400mm	2.6kg

Model: PBM 30

Construction

- 1 Support Base with Neodymium Magnet Ø60 mm force of attraction 110 Kg
- 2 Detachment Eccentric Cam of Magnetic Base
- 3 Support Arm with Double Articulation, for complete Shield Adjustment
- 4 Shield - Shockproof and Oil-Resistant, with aluminium Structure
- 5 Knobs for Articulations Lock

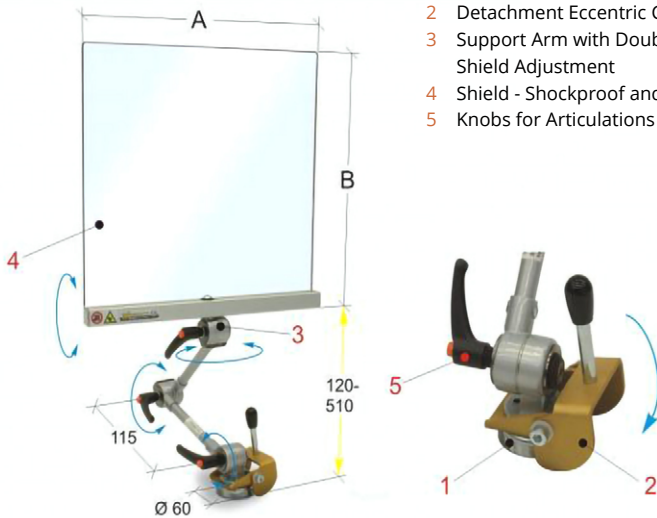

93/1844

PBM 30 - Machine Guard with Magnetic Base

- The PBM 30 comes with an incredibly powerful Neodymium Magnet which Ensures the Guard can be used in multiple operations
- The force of the Magnet Enables the Guard to be Attached Vertically and also Hung above the machine
- Can be positioned in any direction, which is enabled by the flexibility of the three joints on the guard arm
- Suitable to be used on Metal Work Surfaces and Machine Bases.
- The flexible features of the PBM 30 enable a broad use. Usage examples:
 - Grinding
 - Component assembly
 - Operations where quick intervention is needed
- Guard is ideal for Operations where No Electric interlock is required
- Guard is easy to install and operator friendly

Our Guards

Screens

Anti-Splash Screen



Swivel & Brake Castor

Product Details

- A free standing adjustable safety shield mounted on 50mm castors (swivel and braked).
- Constructed in 25mm x 25mm mild steel support tubes.
- Safety shield size 1200 x 800 x 5mm thick polycarbonate, angled top and bottom to deflect spray and any flying objects.
- Adjustable by two floral knobs to a maximum height of 1.7 metres.

We are pleased to quote for other Screen Sizes



Our Guards

Hydraulic Machines

PBF 10 - Hydraulic Press Safety Guard



Model: PBF 10

Complete Guards

Part No.	A	B	Weight
PBF 10/350	350mm	300mm	5.5kg
PBF 10/435	400mm	350mm	5.8kg

Construction

- 1 Angular Anchorage Stirrup in Pressed Steel
- 2 Articulated Arms in Tubular Steel
- 3 Rubbing Articulation with Friction Disc
- 4 Angular Junction for Vertical Turnover of the Shield
- 5 Main Box with 180° Rotation and Safety Microswitch
- 6 Shield Opening Release Knob
- 7 Shield Structure in Aluminium Profile
- 8 Shield - Shockproof and Oil-Resistant

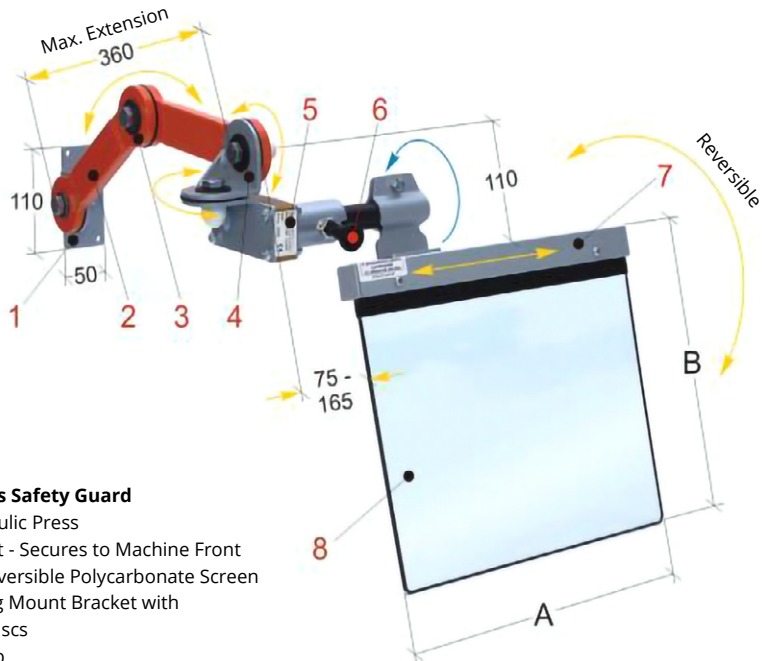

PBF 10 - Hydraulic Press Safety Guard

- Machine Type - Hydraulic Press
- Method of attachment - Secures to Machine Front
- Wide Visibility with Reversible Polycarbonate Screen
- Tubular Steel Levelling Mount Bracket with Articulation Friction Discs
- Opening Release Knob
- Operation - Fully Adjustable in any direction
- Supplied with 180° Safety Microswitch

Our Guards

Hydraulic Machines

Hydraulic Press Sliding Guard



Hydraulic Press - Sliding Guard

Complete Guard

Part No.	Model
10750	Hydraulic Press - Sliding Guard

Product Details

- Machine Type - Hydraulic Press
- Manufactured from Tubular Steel with 5mm Polycarbonate
- Fitted to Table with Adjustable Rails - Fixings Supplied
- Left Hand side, Right Hand side or Both - Available on request

We require Sizes to ensure a correct fit to your Machine

HOW TO MEASURE MACHINE TABLE

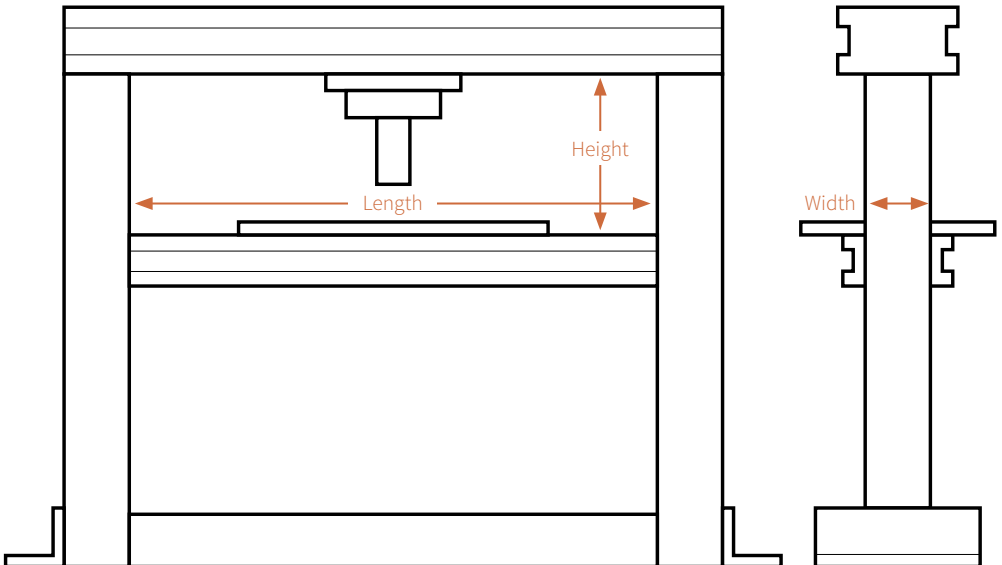

HEIGHT / MM:

LENGTH / MM:

WIDTH / MM:

Please State if there are any Handles that need to be Accessed from the Front of the Machine and where they are Located

Our Guards

Bandsaw Machines

Bandsaw Guard



Bandsaw Guard

Construction

- 1 5mm Steel Mounting Plate.
- 2 260mm up & down adjustment.
- 3 Fast and easy adjustment of the visor position by the knob on the right and side.
- 4 In and out adjustment.
- 5 1" Steel Tube with 16mm Bar.
- 6 Visor angle is adjustable by loosening the two 10mm bolts.
- 7 5mm Polycarbonate Visor.
- 8 The Guard is finished in Yellow Powdercoat.



Complete Guard

Part No.	Model
13015	Bandsaw Guard

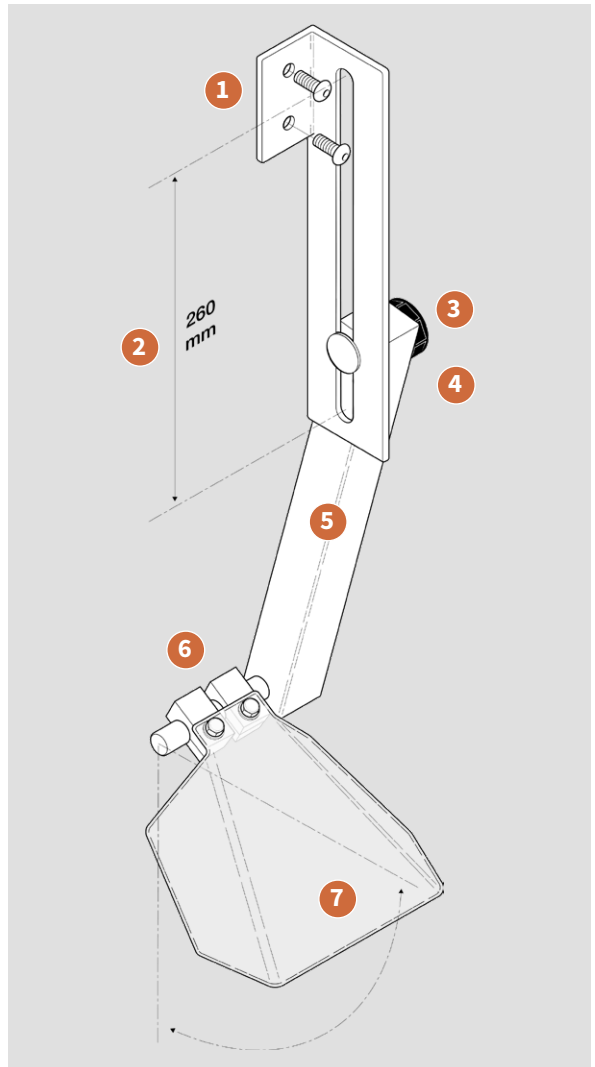

Our Guards

Slotting Machines

Slotting Machine Guard



Slotting Machine Guard

PST 01 - Slotting Machine Guard

- The Guard Protects from Direct Frontal Contact with moving parts and the projection of debris and coolant.
- The Guard is Reversible and can be Mounted to either side of the machine.
- Adaptability to your machine is Guaranteed as the screen is height adjustable.
- Equipped with a completely transparent monolithic shield, made using top quality polycarbonate ensuring excellent visibility and "shockproof" resistance.
- We can tailor make brackets, mounts and modify standard guards as required.
- Does not restrict production and ensures maximum safety.
- Complete with safety micro-switch conforming to EN 1088.
- Machine guards are in conformance with P.U.W.E.R (1998) regulations and come with a certificate of conformity.

Complete Guards

Part No.	A	B	C	D	E	Weight
PST 01/240	400	400	200	250	600	7.7kg
PST 01/260	400	600	200	250	800	8.9kg

Construction

- 1 Levelling Anchorage Stirrup in Tubular Steel
- 2 Depth Adjustable Safety Guard Support
- 3 Safety Microswitch Main box 180° Rotation n. 2 NC contacts
- 4 Adjustable Shield Arm Fixing Clamps in Pressed Steel
- 5 Vertical Shield Support Arm in Tubular Stainless Steel
- 6 Semi Hexagonal Monolithic Shield in Thick Plastic Shockproof and Oil Resistant

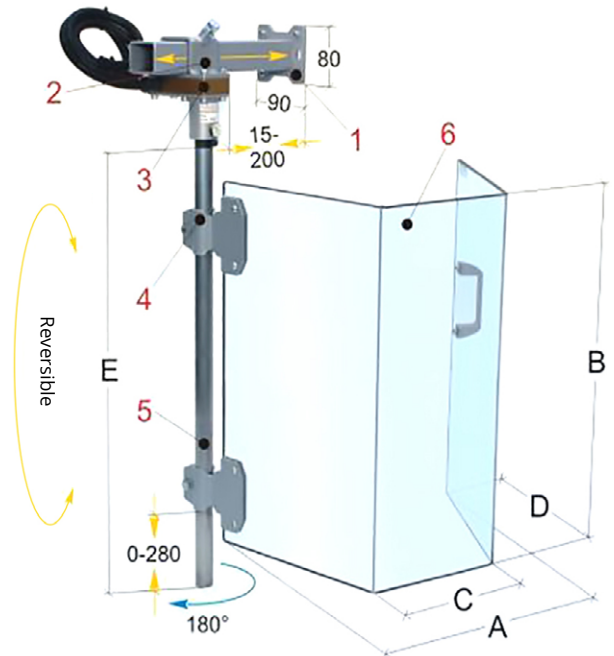

Emergency Braking Systems



Model: QS UNIT

Product Details

QS10 Units are suitable for Dual Wound, D.O.L. Motors.

Supply Voltage

From 240 Volts Single Phase to 415 Volts 3 Phase 50 Hz.

Standard Models

- **QS2:** For Motors up to 3 h.p. (2.2kW) D.O.L. 3 Phase or up to 0.75 h.p. (0.55kW) Single Phase.
- **QS5:** For Motors up to 7.5 h.p. D.O.L. 3 Phase or up to 1 h.p. Single Phase.
- **QS10:** For Motors up to 10 h.p. (7.5kW) D.O.L. 3 Phase or up to 2 h.p. (1.5kW) Single Phase.

The Quickstop DC Injection Braking Unit provides a rapid or controlled stop every time the tripping device is activated. This could be a trip switch, stop button or any device which opens its contact when operated.



Open QS Unit - Electronic Type

The Electronic D.C. Injection Units have a 240V Control Circuit.
The Transformer D.C. Injection Units have a 110V Control Circuit.

The device works by cutting the A.C. Supply to the electric motor and then injecting D.C. into the motor windings. This causes a magnetic field in the stator that causes the rotor in the motor to stop.

Part No.	Motor	Description
50001	0-3 h.p.	Direct On Line (QS2) 300mm x 200mm x 150mm
50003	0-7.5 h.p.	Direct On Line (QS5) 300mm x 200mm x 150mm
50002	0-10 h.p.	Direct On Line (QS10) 300mm x 200mm x 150mm
-	0-10 h.p.	Direct On Line (QS10) Transformer type 400mm x 400mm x 200mm

Our range comprises of two types - a transformer rectifier type and/or an electronic device style.

For rapid stop that is required for a radial drill - the transformer rectifier type is recommended because it has a quicker response time. For most other applications - the electronic units are normally suitable.

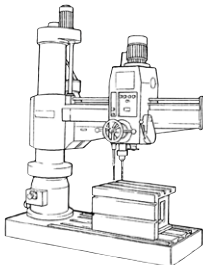

Emergency Braking Systems for ALL Types of Machinery including Radial Drillers.

Our Guards

Emergency Stop

Emergency Stop Switches



Model: FOOT SWITCH

Product Details

Industrial Foot/Palm Switch

IP67, UL & CSA Approved. 1 N/O, 1 N/C contacts (10A). Latching.

Part No.	Description
50008	Industrial Foot Switch



Model: ANTENNA SWITCH

Telescopic Antenna Switch

The trip switch is designed to offer protection to operators of radial drilling machines & similar exposed potentially dangerous equipment.

Part No.	Description
50005	Telescopic Antenna Switch



Switch Post

Enables positioning of an "E Stop Switch" to any preferred working area at knee or hand height.

PLEASE ASK FOR MORE INFORMATION

Our Guards

Emergency Stop

Emergency Stop Switches



Product Details

Foot Operated Trip Switch - F12

This Compact Foot Switch is intended for Smaller Machines such as Drills, Grinders, Polishers and small Milling Machines.

Foot Operated Kick Plate Trip Switch - KP150

A Larger Kick Plate Switch suitable for Larger Machines such as Lathes, Bending Rolls, Cylindrical Grinders & Milling Machines.

Model: FOOT SWITCH - F12

F12:

- This Compact Foot Switch is intended for Smaller Machines such as Drills, Grinders, Polishers and small Milling Machines.

KP150:

- A Larger Kick Plate Switch suitable for Larger Machines such as Lathes, Bending Rolls, Cylindrical Grinders & Milling Machines.



Model: KICK PLATE SWITCH - KP150

Part No.	A	B	C
(F12) 33900	300mm	60mm	70mm
KP150/500	500mm	160mm	60mm
KP150/1000	1000mm	160mm	60mm
KP150/1500	1500mm	160mm	60mm
KP150/2000	2000mm	160mm	60mm

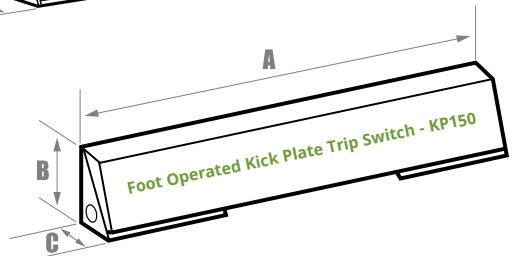
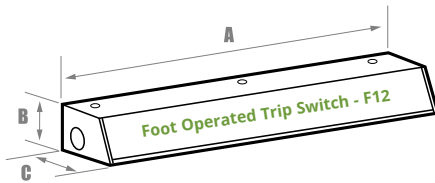

Specifications:

- Designed specifically for Emergency Stop Applications.
- Fully Compliant with B.S.E.N. 60204 & B.S. 5305 and compatible with 'Driveloc' D.C. Injection Motor Brakes.

Enclosure:

- Robust Steel with a Tough Epoxy. Polyester Coating.

Contacts:

- Forced Break Changeover Type.

Rated:

- 500 Volts. 10amp. A.C. in an IP55 Enclosure.

Our Guards

Machine Mounts

Machine Floor Mounts



Product Details

- Reduced Vibration
- Absorb noise and shock
- Simplify Machine installed by eliminating the need for costly foundation and holding down bolts
- Fitted in minutes

Machine Mounts combine the dual but independently function of Damping and Levelling.

Highly effective damping stems from the solid base consisting of a galvanised steel cover plate and a flexible body which is moulded in acid oil, heat and age resistant chloroprene material which is suitable for any solid floor.

A vacuum is formed in the recess of the base by the pressure of the installed machine and a suction pressure is created that will prevent the machine from moving even when strong forces are applied in the horizontal plane.



MACHINE MOUNT

Part No.	Ø (mm)	Min Height (mm)	Adjust Height (mm)	Bolt Thread	Bolt Length (mm)	General Load per Mount (kg)	Presses: Load per Mount 160-200 stroke/ min	Presses: Load per Mount 125-160 stroke/ min	Presses: Load per Mount <125 stroke/ min
220001	80	35	35 - 47	M12 x 1,25	120	50 - 500	50 - 120kg	60 - 140kg	70 - 200kg
220002	120	40	40 - 53	M16 x 1,5	120	400 - 1000	100 - 250kg	120 - 350kg	200 - 400kg
220003	160	50	50 - 65	M20 x 1,5	170	800 - 2000	250 - 725kg	350 - 1100kg	400 - 1400kg
220004	160	60	60 - 75	M20 x 1,5	170	1500 - 4000	500 - 1400kg	750 - 2100kg	1000 - 2800kg

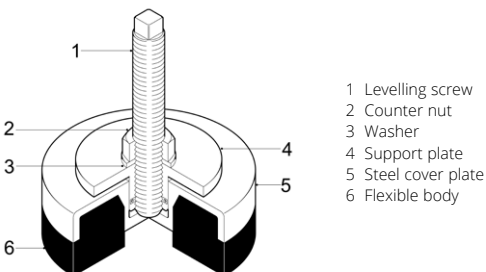

- 1 Levelling screw
- 2 Counter nut
- 3 Washer
- 4 Support plate
- 5 Steel cover plate
- 6 Flexible body

To Determine Mount Required Apply the Following Formula:

Gross Machine Weight and Tooling is 1016 Kgs.

With 4 mounting points this is a load of 254 Kgs per mounts therefore use Model 220001.

All Machines

Spares

Components, Visors, Pin-sets & Castings



We supply a full range of spare and replacement parts for all of our products, including visors, adjustable pin sets, (these often get lost) and other items such as broken castings and steelwork.

Spare & Replacement Parts

Please contact us for a full list, most of which are normally held in stock.

Our Guards

Bespoke Guards

Bespoke Guarding

Product Details

In conjunction with our standard guard range we also undertake design and production of bespoke and perimeter fencing for special purpose machinery such as Borers, Lathes, CNC and Robotics.



BESPOKE GUARDS

