

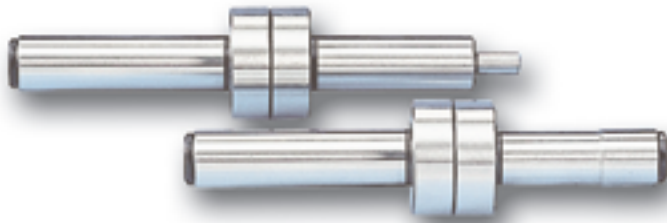

Touch Point Sensor

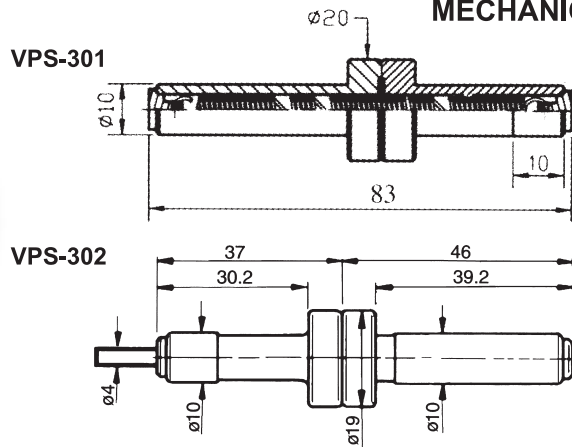

MECHANICAL TYPE



- Accuracy of zero point to point is within 0.003mm.
- R.P.M. within 450-600.
- Max. flange can be clear your sight sense.
- MIN. (4mm) can be test mini hole for your workpiece.

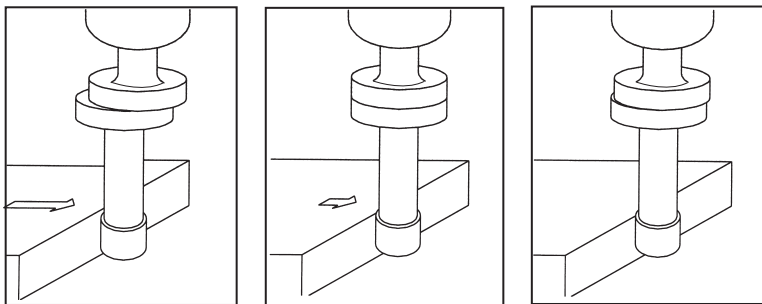

Spindle runs about 500rpm. move spindle closed to measuring surface.

When measuring probe touches workpiece, it looks in one part.

When the probe and shank are in alignment, probe will slide out of rotating center. Now, the center spindle is located 5mm away from measuring surface.

ORDER NO.	MATERIAL	HARDNESS	WEIGHT (kg)	CODE NO.
VPS-301	ALLOY	HRC 56°	0.03	3402-100
VPS-302	STEEL	HRC 56°	0.03	3402-101
VPS-301S	STAINLESS	HRC 60°	0.03	3402-102
VPS-302S	STAINLESS	HRC 60°	0.03	3402-103
VPS-301C	CERAMIC	HRC 60°		3402-104



CERAMIC TYPE VPS-301C



Centering Indicator

- RPM Within 800.
- Use for Internal or External.
- Use for Vertical or Horizontal.
- While Spindle Rotates, With Stop bar for Fixing The Head The centering Indicator Always faces the operator.

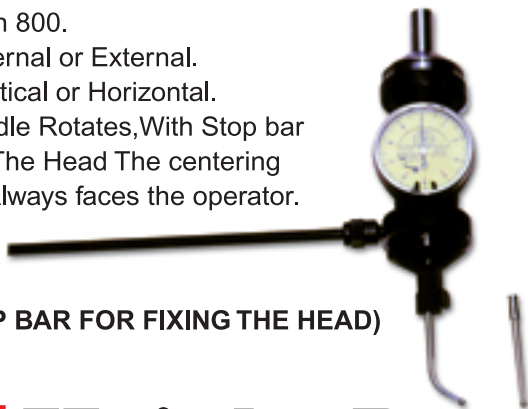

ORDER NO. VCI-170

CODE NO. 3402-130

Shank	10 ^ø	m/m
Length	170	m/m
Internal	4 ^ø ~ 108 ^ø	m/m
External	0 ^ø ~ 108 ^ø	m/m
Min. Indicator	0.01	m/m
Indicator Range	0 ~ 6	m/m
Weight	0.4 kgs	

(WITH STOP BAR FOR FIXING THE HEAD)



Height Presetter

OPTICAL TYPE



HP-50Z BATTERY
LR4476AG13
1SET/2PCS
HP-50ZM
LR44
1SET/2PCS

	STANDARD TYPE	WITH MAGNETIC BASE
ORDER NO.	HP-50Z	HP-50ZM
CODE NO.	3403-001	3403-002

- Height 50mm.
- With magnetic base.
- The red lamp will be lighted up when touched.
- Accuracy 0.005mm
- Combined vertical and horizontal in a unit.
- Weight: 0.7kgs