

**FLANSCH FERTIGBEARBEITET  
FÜR FUTTER MIT FEINEINSTELLUNG**  
FULLY MACHINED ADAPTER PLATES  
FOR CHUCKS WITH FINE ADJUSTMENT

**8215**  
DIN 55026

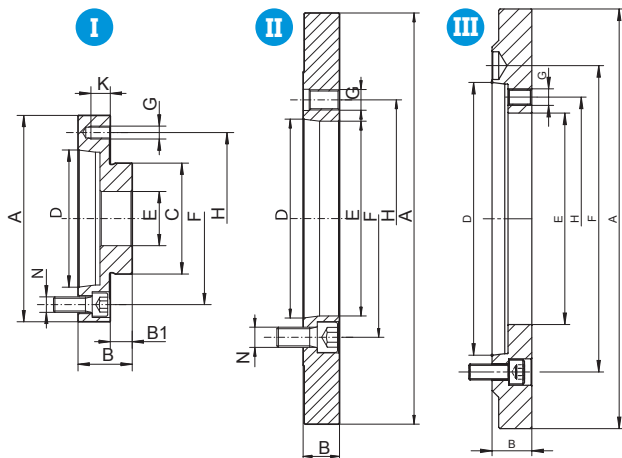

Artikel Nr.	W	KK 1:4	Z	A	B	B1	C	D	E	F	G	H	K	kg
		ST 1:4												
358215050600	100	3	I	100,00	40	12	45,00	53,975	20,0	70,6	M8	83,0	14	1,6
358215051900	100	4	I	105,00	40	12	45,00	63,513	20,0	82,6	M8	83,0	14	1,5
358215064900	125	4	I	125,00	36	14	55,00	63,513	35,0	82,6	M8	108,0	22	2,2
358215070000	125	5	I	125,00	36	14	55,00	82,563	35,0	104,8	M8	108,0	22	1,9
358215073800	160	3	I	160,00	45	16	86,00	53,975	42,0	70,6	M10	140,0	20	4,4
358215074000	160	4	I	160,00	45	16	86,00	63,513	42,0	82,6	M10	140,0	29	4,4
358215080100	160	5	I	160,00	37	16	86,00	82,563	42,0	104,8	M10	140,0	21	3,1
358215090300	160	6	I	160,00	42	16	86,00	106,375	42,0	133,4	M10	140,0	26	3,3
358215104900	200	4	I	200,00	33	17	110,00	63,513	55,0	82,6	M10	176,0	16	4,4
358215110000	200	5	I	200,00	33	17	110,00	82,563	55,0	104,8	M10	176,0	16	4,2
358215120100	200	6	I	200,00	45	17	110,00	106,375	55,0	133,4	M10	176,0	28	6,2
358215150700	250	5	I	250,00	38	19	145,00	82,563	76,0	104,8	M12	224,0	19	7,8
358215160900	250	6	I	250,00	38	19	145,00	106,375	76,0	133,4	M12	224,0	19	7,9
358215170000	250	8	I	250,00	46	19	145,00	139,719	76,0	171,4	M12	224,0	26	9,2
358215200900	315	6	I	315,00	38	19	180,00	106,375	103,0	133,4	M16	286,0	19	12,3
358215210000	315	8	I	315,00	46	19	180,00	139,719	103,0	171,4	M16	286,0	27	16,0
358215221500	315	11	I	315,00	55	19	180,00	196,869	103,0	235,0	M16	286,0	36	18,7
358215230400	400	6	II	298,45	35	-	298,45	106,375	136,0	133,4	M16	171,4	35	14,3
358215240600	400	8	II	298,45	37	-	298,45	139,719	136,0	171,4	M16	171,4	29	12,8
358215251000	400	11	II	298,45	48	-	298,45	196,869	136,0	235,0	M16	171,4	27	16,2
358215270100	500	8	II	407,00	36	-	407,00	139,719	136,0	171,4	M20	235,0	36	31,5
358215280300	500	11	II	407,00	36	-	407,00	196,869	192,8	235,0	M20	235,0	36	27,6
358215290500	500	15	II	407,00	52	-	407,00	285,775	190,0	330,2	M20	235,0	52	34,6
358215350900	630	8	II	407,00	36	-	407,00	139,719	136,0	171,4	M20	330,2	36	31,5
358215360000	630	11	II	407,00	36	-	407,00	196,869	192,8	235,0	M20	330,2	36	27,6
358215370200	630	15	II	407,00	52	-	407,00	285,775	252,0	330,2	M20	330,2	52	29,6
358215380400	800	11	II	635,00	40	-	635,00	196,869	192,8	235,0	M24	368,3	40	86,5
358215382000	800	15	II	635,00	46	-	635,00	285,775	281,0	330,2	M24	368,3	45	75,4
358215383200	800	20	III	635,00	60	-	635,00	412,775	320,0	463,6	M24	368,3	31	82,4
358215392100	1000	15	II	635,00	45	-	635,00	285,775	281,0	330,2	M24	463,6	45	74,7
358215393400	1000	20	II	635,00	45	-	635,00	412,775	408,0	463,6	M24	463,6	45	59,2
358215412800	1250	15	II	720,00	50	-	720,00	285,775	281,0	330,2	M30	647,6	50	120,0
358215413000	1250	20	II	720,00	50	-	720,00	412,775	408,0	463,6	M30	647,6	50	93,0

W - Futterdurchmesser • Chuck diameter

Z - Form der Flansche • Adapter form