

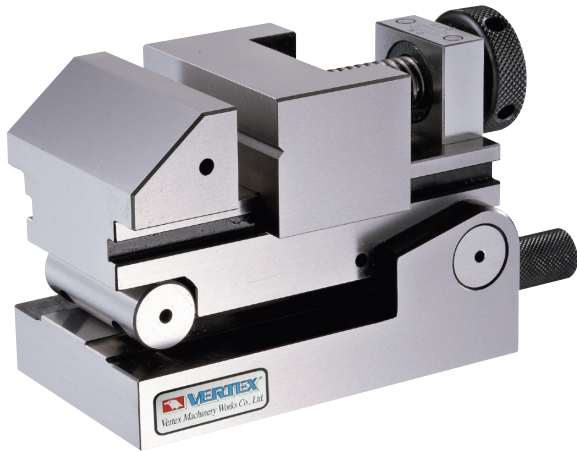

# Precision Sine Vise



THE CLAMP HANDLE IS PLACED UNDER WORK PIECE.



HARDNESS HRC 60°, SKS3  
PARALLELISM 0.003 / 100 mm  
SQUARENESS 0.005 / 100 mm

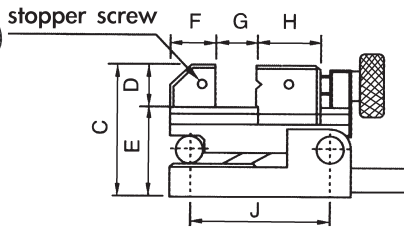
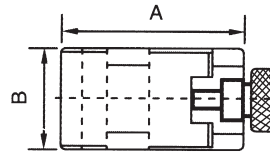

ORDER NO.	CODE NO.
SVC-100	2003-090

Unit:mm

A	130
B	70
C	93
D	30
E	63
F	33
G	45
H	45
I	M5
J	100
Max.angle	46°
Weight(kgs)	5.5



# Precision Sine Vise

HARDNESS HRC 60°, SKS3  
PARALLELISM 0.003 / 100 mm  
SQUARENESS 0.005 / 100 mm

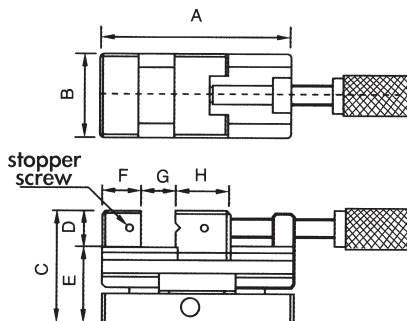
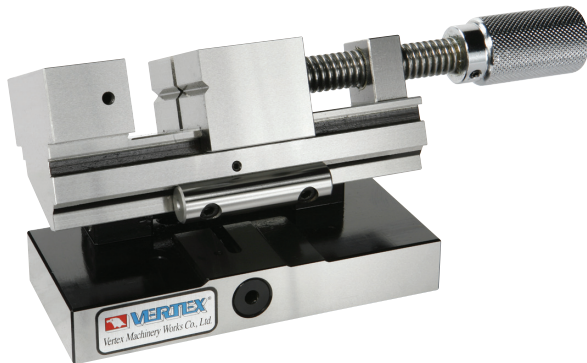

ORDER NO.	CODE NO.
SVL-50	2003-100

Unit:mm

A	160
B	73
C	93
D	30
E	63
F	33
G	80
H	45
I	M5
Max.angle	46°
Weight(kgs)	6.6



# Two Way Vise

2 WAYS

HARDNESS HRC 60°, SKS3  
PARALLELISM 0.003 / 100 mm  
SQUARENESS 0.005 / 100 mm

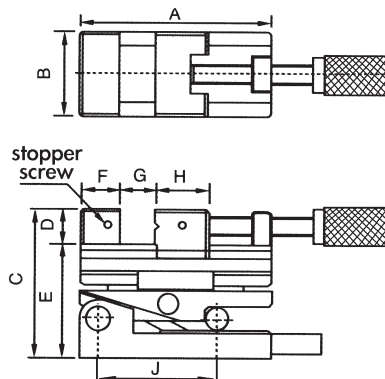

ORDER NO.	CODE NO.
SVS-100	2003-110

Unit:mm

A	160
B	73
C	124
D	30
E	94
F	33
G	80
H	45
I	M5
J	100
Max.angle	46°
Weight(kgs)	8.3