



ALBRECHT

CHUCK REFURBISHING

Send It In or Do It Yourself

Quality Without Compromise

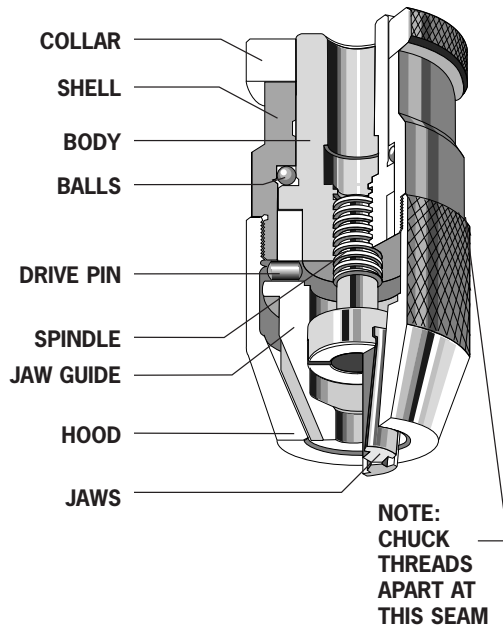

Many customers refurbish their own chucks by following these simple instructions. If you have questions regarding the refurbishing process, please call one of our applications engineers at 1-800-468-3008, or visit www.albrechtchucks.com.

- Remove collar from chuck
- There is an invisible seam between the hood and shell. Hold chuck by the shell in a vise with soft jaws and loosen hood with a strap wrench – RH thread
- Once hood has been loosened, unscrew by hand to prevent distortion
- Slide jaws out of jaw guide and remove guide
- Remove body and spindle assembly to expose balls
- Clean all parts with a mild solvent
- Replace worn or damaged parts
- Reverse steps for assembly

**Caution – do not lubricate acme thread on body/spindle assembly.
Thread must be clean and dry for chuck to work correctly.**

If you prefer to send you chucks back to our factory for refurbishing, please send them to the address listed in this catalog. Be sure to include your name, telephone number, and either a fax number or email address so we can send you a free, no-obligation quotation. If our technicians determine that a chuck is beyond reasonable refurbishing condition, you will be offered a brand new Albrecht chuck at a discounted price.