

## Type 6512 - MACHINE VISE WITH MOVABLE REAR JAW

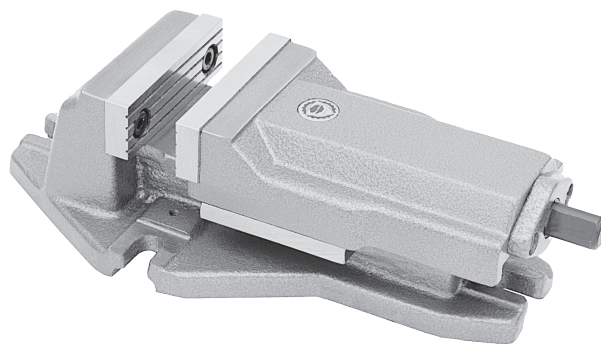
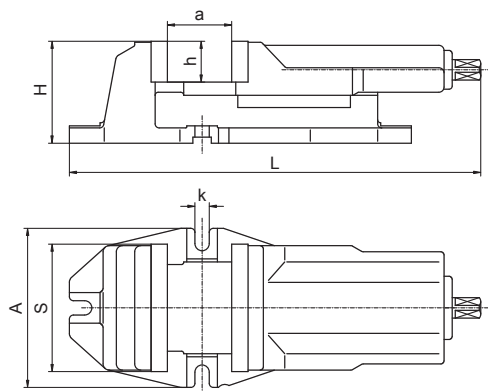

**Features:**

- Thrust bearing in the power transmission enables easy operation
- Removable grooved jaw inserts are hardened and ground, ensuring longer life with maintained accuracy and repeatability
- Lead screw protected against dirt and chips
- Long guidance of movable jaw
- Body and movable jaw are high quality castings
- Low, sturdy design

**Application:**

- Designed for use with milling machines, drill presses, etc.

**Standard accessories:**

- Handcrank
- Slot nuts

Size S	A	H	L	a max.	h	k	Max. clamping force [daN]	Weight [kg]
100	156	84	294	80	32	14	2500	9,9
125	156	100	347	95	40	14	3500	15,9
160	193	121	423	125	50	18	4000	29,0
200	256	147	515	160	63	18	5500	56,0
250	316	174	615	200	80	22	6200	71,0

Example of order: 6512-100

## Type 6537 - MACHINE VISE SWIVEL WITH MOVABLE REAR JAW

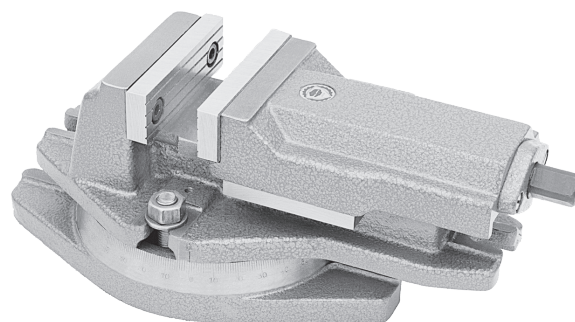
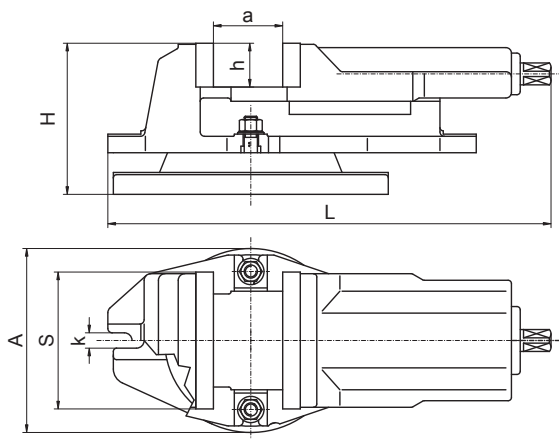

Constructed in the same manner as above, except vises are mounted on swivel bases graduated 360°

Size S	A	H	L	a max.	h	k	Max. clamping force [daN]	Weight [kg]
100	168	122	309	80	32	14	2500	13,8
125	168	138	347	95	40	14	3500	20,0
160	212	170	423	125	50	18	4000	36,0
200	271	197	515	160	63	18	5500	70,0
250	360	228	615	200	80	22	6200	99,0

Example of order: 6537-100